

Contents

| | | |
|----------|--------------------------------------|-----------|
| 1 | Instructions | 48 |
| 1.1 | General safety instructions | 48 |
| 1.2 | Manufacturer liability | 52 |
| 1.3 | Appliance purpose | 52 |
| 1.4 | Identification plate | 52 |
| 1.5 | This user manual | 53 |
| 1.6 | Disposal | 53 |
| 1.7 | How to read the user manual | 54 |
| 1.8 | To save energy | 54 |
| 2 | Description | 55 |
| 2.1 | General Description | 55 |
| 2.2 | Control panel | 56 |
| 2.3 | Cooking hob | 57 |
| 2.4 | Other parts | 57 |
| 2.5 | Available accessories | 58 |
| 3 | Use | 59 |
| 3.1 | Instructions | 59 |
| 3.2 | First use | 60 |
| 3.3 | Using the accessories | 60 |
| 3.4 | Using the hob | 62 |
| 3.5 | Using the ovens | 63 |
| 3.6 | Cooking advice | 64 |
| 3.7 | Programmer clock | 66 |
| 4 | Cleaning and maintenance | 71 |
| 4.1 | Instructions | 71 |
| 4.2 | Cleaning the appliance | 71 |
| 4.3 | Removing the door | 72 |
| 4.4 | Cleaning the door glazing | 72 |
| 4.5 | Extraordinary maintenance | 74 |
| 5 | Installation | 76 |
| 5.1 | Gas connection | 76 |
| 5.2 | Adaptation to different types of gas | 79 |
| 5.3 | Electrical connection | 83 |
| 5.4 | Positioning | 85 |
| 5.5 | Instructions for the installer | 88 |

We advise you to read this manual carefully, which contains all the instructions for maintaining the appliance's aesthetic and functional qualities.

For further information on the product: www.smeg.com



1 Instructions

1.1 General safety instructions

Risk of personal injury

- During use the appliance and its accessible parts become very hot. Keep children well away from the appliance.
- Protect your hands by wearing oven gloves when moving food inside the oven.
- Never try to put out a fire or flames with water: turn off the appliance and smother the flames with a fire blanket or other appropriate cover.
- This appliance can be used by children aged from 8 years and above and persons with reduced physical, sensory or mental capabilities or lack of experience and knowledge if they have been given supervision or instruction concerning use of the appliance in a safe way and understand the hazards involved.
- Children must not play with the appliance.
- Keep children under the age of 8 at a safe distance unless they are constantly supervised.
- Keep children under the age of 8 away from the appliance when it is in use.
- Cleaning and maintenance must not be carried out by unsupervised children.
- Make sure that the flame-spreader crowns are correctly positioned in their seats with their respective burner caps.
- Be aware of how rapidly the cooking zones heat up. Do not place empty pans on the heat. Danger of overheating.
- Cooking process should always be kept under control. A short cooking process must be continuously surveyed.
- Fats and oils can catch fire if they overheat. Do not leave the appliance unattended while preparing foods containing oils or fats. If fats or oils catch fire, never put water on them. Place the lid on the pan and turn off the relevant cooking zone.
- While cooking do not place metal objects, such as cutlery or dishes on the hob surface as they may overheat.
- Do not insert pointed metal objects (cutlery or utensils) into the slots in the appliance.
- Do not pour water directly on very hot trays.



- Keep the oven door closed during cooking.
- If you need to move food or at the end of cooking, open the door 5 cm for a few seconds, let the steam come out, then open it fully.
- Do not open the storage compartment (where present) when the oven is on and still hot.
- The items inside the storage compartment could be very hot after using the oven.
- Switch off the appliance after use.
- Do not pull the cable to remove the plug.
- **DO NOT USE OR STORE FLAMMABLE MATERIALS IN THE STORAGE COMPARTMENT (IF AVAILABLE) OR NEAR THE APPLIANCE.**
- **DO NOT USE AEROSOLS IN THE VICINITY OF THIS APPLIANCE WHILST IT IS IN USE.**
- **DO NOT MODIFY THIS APPLIANCE.**
- Before any operation on the appliance (installation, maintenance, positioning or movement) always wear PPM.
- Before performing any operation on the appliance, switch off the power supply.
- Have qualified personnel carry out installation and assistance interventions according to the standards in force.
- Do not try to repair the appliance yourself or without the intervention of a qualified technician.
- In order to avoid hazard, if the power supply cable is damaged, contact technical support and they will replace it.

Risk of damaging the appliance

- Do not use harsh abrasive cleaners or sharp metal scrapers to clean the oven door glass since they can scratch the surface, which may result in shattering of the glass.
- Use wooden or plastic utensils.
- Do not use steam jets to clean the appliance.
- Do not obstruct ventilation openings and heat dispersal slots.



Instructions

- Do not sit on the appliance.
- Racks and trays should be inserted as far as they will go into the side guides. The mechanical safety locks that prevent them from being removed must face downwards and towards the back of the oven.

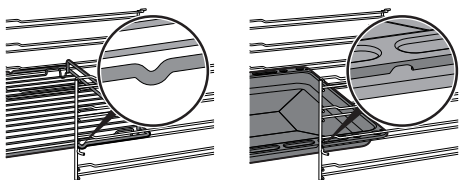

- Never leave the appliance unattended during cooking operations where fats or oils could overheat and take fire. Be very careful
- Danger of fire: do not store items on the cooking surfaces.
- Do not spray any spray products near the oven.
- **DO NOT USE THE APPLIANCE TO HEAT ROOMS FOR ANY REASON.**
- Do not use plastic cookware or containers for cooking.
- Do not place sealed tins or containers in the oven cavity.
- Remove all trays and racks which are not required during cooking.
- Do not cover the bottom of the oven cavity with aluminium or tin foil sheets.
- Do not place pans or trays directly on the bottom of the oven cavity.
- If you wish to use greaseproof paper, place it so that it will not interfere with the hot air circulation inside the oven.
- Do not use the open door to place pans or trays on the internal glazing pane.
- Cooking vessels or griddle plates should be placed inside the perimeter of the hob.
- All pans must have smooth, flat bottoms.
- If any liquid does boil over or spill, remove the excess from the hob.
- Take care not to spill acid substances such as lemon juice or vinegar on the hob.
- Do not use steam jets to clean the appliance.



- Do not put empty pans or frying pans on switched on cooking zones.
- Do not use rough or abrasive materials or sharp metal scrapers.
- Do not use cleaning products containing chlorine, ammonia or bleach on parts made of steel or that have metallic surface finishes (e.g. anodizing, nickel- or chromium-plating).
- Do not wash the removable components such as the hob grids, flame-spreader crowns and burner caps in a dishwasher.
- Never use the oven door to lever the appliance into place when fitting.
- Avoid exerting too much pressure on the door when open.
- Do not use the handle to lift or move this appliance.
- Position the appliance into the cabinet cut-out with the help of a second person.
- To prevent any possible overheating, the appliance should not be installed behind a decoration door or a panel.
- Before installation, make sure that the local distribution conditions (nature and pressure of the gas) and the adjustment of the appliance are compatible.
- This appliance is not connected to an exhaust system for combustion products. It must be installed and connected in compliance with the current installation regulations. Special attention should be paid to the relevant requirements as for ventilation.
- The adjustment conditions for this appliance are shown on the gas setting label.
- Have the gas connection performed by authorised staff.

Installation

- **THIS APPLIANCE MUST NOT BE INSTALLED IN A BOAT OR CARAVAN.**
- This appliance must not be installed on a pedestal.
- Installation using a hose must be carried out so that the length of the hose does not exceed 2 metres when fully extended for steel hoses and 1.5 metres for rubber hoses.



Instructions

- The hoses should not come into contact with moving parts and should not be crushed in any way.
- If required, use a pressure regulator that complies with current regulations.
- After carrying out any operation, check that the tightening torque of gas connections is between 10 Nm and 15 Nm.
- At the end of the installation, check for any leaks with a soapy solution, never with a flame.
- Have the electrical connection performed by authorised technicians.
- The appliance must be connected to ground in compliance with electrical system safety standards.
- Use cables withstanding a temperature of at least 90 °C.
- The tightening torque of the screws of the terminal board leads must be 1.5 - 2 Nm.
- Do not rest any weight or sit on the open door of the appliance.
- Take care that no objects are stuck in the doors.

1.2 Manufacturer liability

The manufacturer declines all liability for damage to persons or property caused by:

- use of the appliance other than that specified;
- failure to comply with the instructions in the user manual;
- tampering with any part of the appliance;
- use of non-original spare parts.

1.3 Appliance purpose

- This appliance is intended for cooking food in the home environment. Every other use is considered inappropriate.
- The appliance is not designed to operate with external timers or with remote-control systems.

1.4 Identification plate

The identification plate bears the technical data, serial number and brand name of the appliance. Do not remove the identification plate for any reason.

For this appliance

- Ensure that the appliance is switched off before replacing the bulb.



1.5 This user manual

This user manual is an integral part of the appliance and must therefore be kept in its entirety and within the user's reach for the whole working life of the appliance.

Read this user manual carefully before using the appliance.

1.6 Disposal



This appliance conforms to the WEEE European directive (2012/19/EU) and must be

disposed of separately from other waste at the end of its service life.

The appliance does not contain substances in quantities sufficient to be considered hazardous to health and the environment, in accordance with current European directives.

To dispose of the appliance:

- Cut the power supply cable and remove it along with the plug.



Power voltage

Danger of electrocution

- Disconnect the mains power supply.
- Unplug the appliance.

- Deliver the appliance to the appropriate recycling centre for electrical and electronic equipment waste, or return it to the retailer when purchasing an equivalent product, on a one for one basis.

Our appliances are packaged in non-polluting and recyclable materials.

- Deliver the packing materials to the appropriate recycling centre.



Plastic packaging

Danger of suffocation

- Do not leave the packaging or any part of it unattended.
- Do not let children play with the plastic bags.



Instructions

1.7 How to read the user manual

This user manual uses the following reading conventions:

Instructions



General information on this user manual, on safety and final disposal.

Description



Description of the appliance and its accessories.

Use



Information on the use of the appliance and its accessories.

Cleaning and maintenance



Information for proper cleaning and maintenance of the appliance.

Installation



Information for the qualified technician: Installation, operation and inspection.



Safety instructions



Information



Advice

1.8 To save energy

- Only preheat the appliance if the recipe requires you to do so.
- Unless otherwise indicated on the package, defrost frozen foods before placing them in the oven.
- When cooking several types of food it is recommended to cook the foods one after the other to make the best use of the already hot oven.
- Use dark metal moulds: They help to absorb the heat better.
- Remove all trays and racks which are not required during cooking.
- Stop cooking a few minutes before the time normally used. Cooking will continue for the remaining minutes with the heat which has accumulated inside the oven.
- Reduce any opening of the door to a minimum to avoid heat dispersal.
- Keep the inside of the oven clean at all times.

1. Sequence of instructions for use.

- Standalone instruction.



2 Description

2.1 General Description

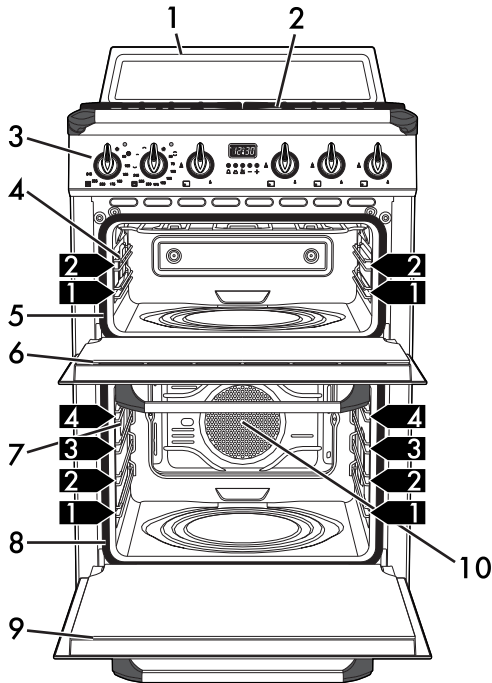

- 1 Upstand
- 2 Cooking hob
- 3 Control panel
- 4 Auxiliary oven light
- 5 Auxiliary oven seal
- 6 Auxiliary oven door

- 7 Main oven light
- 8 Main oven seal
- 9 Main oven door
- 10 Fan

1,2,3 → Rack/tray support frame shelf

EN



Description

2.2 Control panel

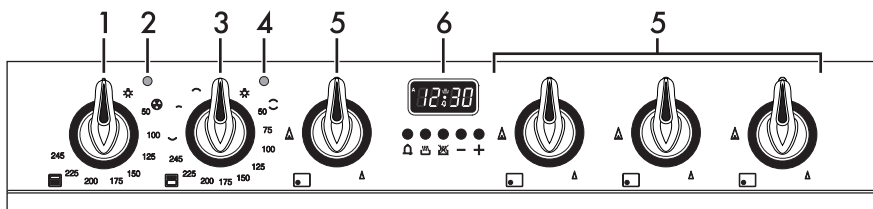

1 Main oven knob

Allows you to turn on the light inside the main oven or set a fan-assisted cooking temperature between 50°C and 245°C.

2 Main oven indicator light

The indicator light comes on to indicate that the oven is heating up. It turns off as soon as it reaches the set temperature. It flashes regularly to indicate that the temperature set inside the oven is kept constant.

3 Auxiliary oven knob

Allows you to turn on the light inside the oven, set a static cooking temperature of between 50°C and 245°C, or select one of the other functions at maximum temperature.

4 Auxiliary oven indicator light

The indicator light comes on to indicate that the oven is heating up. It turns off as soon as it reaches the set temperature. It flashes regularly to indicate that the temperature set inside the oven is kept constant.

5 Hob burner knobs

Useful for lighting and adjusting the hob burners.

Press and turn the knobs anti-clockwise to the value to light the relative burners. Turn the knobs to the zone between the maximum and minimum setting to adjust the flame.

Return the knobs to the position to turn off the burners.

6 Programmer clock

Useful for displaying the current time, setting programmed cooking operations and programming the minute minder timer.



2.3 Cooking hob

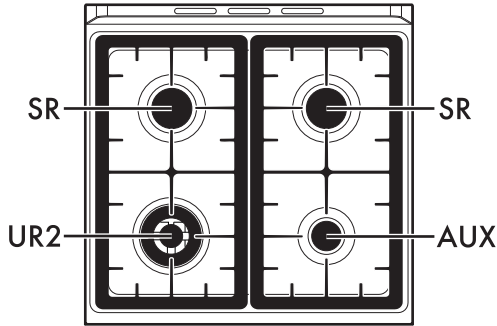

AUX = Auxiliary
SR = Semi-rapid

UR2 = Ultra-rapid

2.4 Other parts

Shelves

The appliance features shelves to position trays and racks at different heights. The insertion heights are indicated from the bottom upwards (see 2.1 General Description).

Interior lighting

The appliance interior lighting comes on:

- When the oven knob (main or auxiliary) is turned to the  position
- When any function is selected

Cooling fan

The fan cools the ovens and comes into operation during cooking.

The fan causes a steady outflow of air that exits from the rear of the appliance and which may continue for a brief period of time even after the appliance has been turned off.

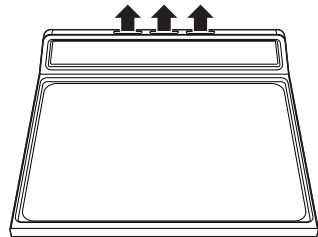



Description

2.5 Available accessories



Some models are not provided with all accessories.

Rack

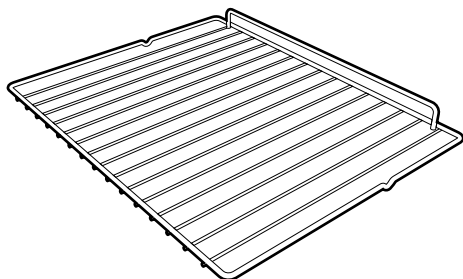
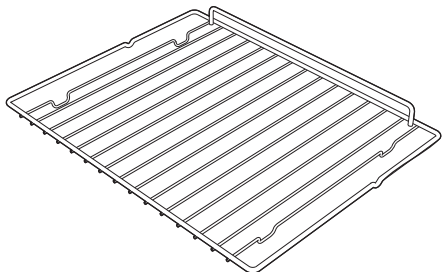

Useful for supporting containers with food during cooking.

Tray rack

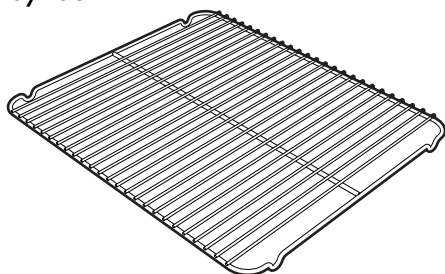

To be placed over the top of the tray; for cooking foods which may drip.

Tray

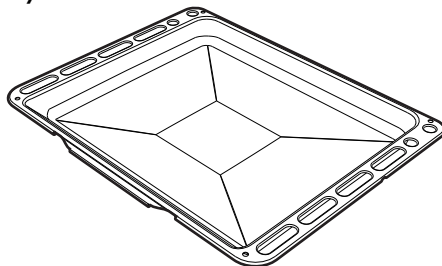

Useful for collecting fat from foods placed on the rack above and for cooking pies, pizzas and baked desserts.

Ring reducers

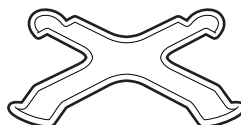

Useful when using small cookware.

WOK ring

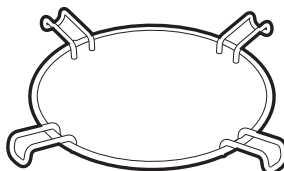

Useful when using a wok.



The accessories intended to come into contact with food are made of materials that comply with the provisions of current legislation.



Supplied and optional accessories can be requested to Authorised Assistance Centres. Use only original accessories supplied by the manufacturer.



3 Use

3.1 Instructions



Improper use Danger of burns

- Make sure that the flame-spreader crowns are correctly positioned in their housings with their respective burner caps.
- Oils and fats could catch fire if overheated. Be very careful.



High temperature inside the oven during use Danger of burns

- Keep the oven door closed during cooking.
- Protect your hands by wearing oven gloves when moving food inside the oven.
- Do not touch the heating elements in the oven.
- Do not pour water directly onto very hot trays.
- Do not allow children younger than 8 years old to come near the appliance when in operation.
- If you need to move food or at the end of cooking, open the door 5 cm for a few seconds, let the steam come out, then open it fully.



High temperature inside the oven cavity

Danger of fire or explosion

- Do not spray any spray products near the appliance.
- Do not use or leave flammable materials near the appliance.
- Do not use plastic kitchenware or containers when cooking food.
- Do not put sealed tins or containers in the oven.
- Do not leave the appliance unattended during cooking operations where fats or oils could be released.
- Remove all trays and racks which are not required during cooking.



Improper use

Risk of damage to surfaces

- Do not cover the bottom of the oven cavity with aluminium or tin foil sheets.
- If you wish to use greaseproof paper, place it so that it will not interfere with the hot air circulation inside the oven.
- Do not place pans or trays directly on the bottom of the oven cavity.
- Do not use the open door to rest pans or trays on the internal glass pane.
- Do not pour water directly onto very hot trays.
- Cooking vessels or griddle plates should be placed inside the perimeter of the hob.
- All pans must have smooth, flat bottoms.
- If any liquid does boil over or spill, remove the excess from the hob.

3.2 First use

1. Remove any protective film from the outside or inside of the appliance, including accessories.
2. Remove any labels (apart from the technical data plate) from the accessories and from the cooking compartments.
3. Remove all the accessories from the appliance and clean them (see 4 Cleaning and maintenance). Heat the empty ovens at the maximum temperature to burn off any residues left by the manufacturing process.

3.3 Using the accessories

Tray rack

The tray rack has to be inserted into the tray. In this way fat can be collected separately from the food which is being cooked.

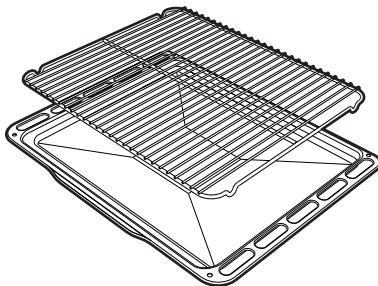



Racks and trays

Racks and trays have to be inserted into the side guides until they come to a complete stop.

- The mechanical safety locks that prevent the rack from being taken out accidentally have to face downwards and towards the oven back.

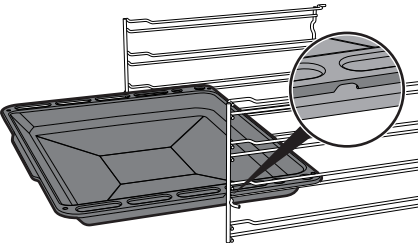
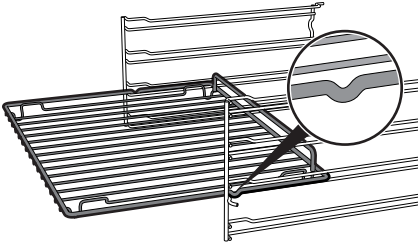

Gently insert racks and trays into the oven until they come to a stop.



Clean the trays before using them for the first time to remove any residues left by the manufacturing process.

Ring reducers

The ring reducers have to be placed on the hob grids. Make sure they are properly placed.

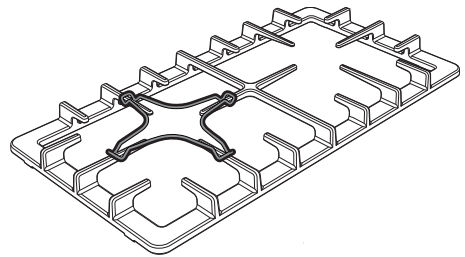
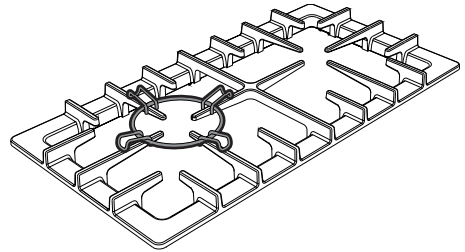



3.4 Using the hob

All the appliance's control and monitoring devices are located together on the front panel. The burner controlled by each knob is shown next to the knob. The appliance is equipped with an electronic ignition device. Simply press the knob and turn it anti-clockwise to the maximum flame symbol, until the burner lights. If the burner does not light in the first 15 seconds, turn the knob to  and wait 60 seconds before trying again. After lighting, keep the knob pressed in for a few seconds to allow the thermocouple to heat up. The burner may go out when the knob is released: In this case, the thermocouple has not heated up sufficiently. Wait a few moments and repeat the operation. Keep the knob pressed in longer.



In case of an accidental switching off, a safety device will be tripped, cutting off the gas supply, even if the gas tap is open. Return the knob to  and wait at least 60 seconds before lighting it again.

Correct positioning of the flame-spreader crowns and burner caps

Before lighting the hob burners, make sure that the flame-spreader crowns are correctly positioned in their housings with their respective burner caps. Make sure that the holes in the flame-spreader crowns are aligned with the igniters and thermocouples.

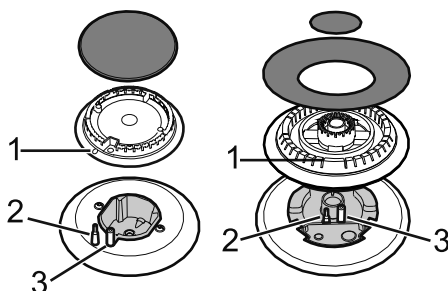

Practical tips for using the hob

For better burner efficiency and to minimise gas consumption, use pans with lids and of suitable size for the burner, so that flames do not reach up the sides of the pan. Once the contents come to the boil, turn down the flame far enough to ensure that the liquid does not boil over.



Cookware diameters:

- Auxiliary: 12 - 14 cm.
- Semi-rapid: 16 - 24 cm.
- Ultra-rapid: 18 - 28 cm.



3.5 Using the ovens

Switching on the main oven

To switch on the main oven:

- Turn the knob clockwise to select the required temperature between 50°C and 245°C.

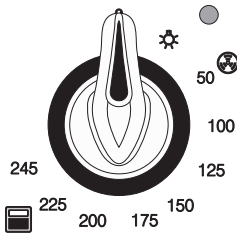

Switching on the auxiliary oven

To switch on the auxiliary oven:

- Turn the knob clockwise to select the required temperature between 50°C and 245°C.
- Turn the knob clockwise further to select on the available functions at maximum temperature.

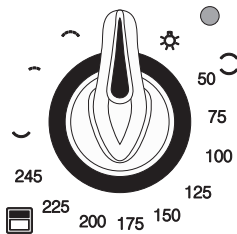

Main oven functions



Fan with circulaire

The combination of the fan and the circulaire heating element (incorporated in the rear of the oven) allows you to cook different foods on several levels, as long as they need the same temperatures and same type of cooking. Hot air circulation ensures instant and even distribution of heat. It will be possible, for instance, to cook fish, vegetables and biscuits simultaneously (on different levels) without odours and flavours mingling.

Auxiliary oven functions



Static

As the heat comes from above and below at the same time, this system is particularly suitable for certain types of food. Traditional cooking, also known as static cooking, is suitable for cooking just one dish at a time. Perfect for all types of roasts, bread and cakes and in any case particularly suitable for fatty meats such as goose and duck.



Lower element

The heat coming just from the bottom allows you to complete the cooking of foods that require a higher bottom temperature, without affecting their browning. Perfect for cakes, pies, tarts and pizzas.



Small grill

Using only the heat released from the central element, this function allows you to grill small portions of meat and fish for making kebabs, toasted sandwiches and any types of grilled vegetable side dishes.



Grill

The heat coming from the grill element gives perfect grilling results above all for thin and medium thickness meat and, in combination with the rotisserie (where fitted), gives the food an even browning at the end of cooking. Perfect for sausages, spare ribs and bacon. This function enables large quantities of food, particularly meat, to be grilled evenly.

3.6 Cooking advice

General advice

- Use a fan assisted function to achieve consistent cooking at several levels.
- It is not possible to shorten cooking times by increasing the temperature (the food could be overcooked on the outside and undercooked on the inside).

Advice for cooking meat

- Cooking times vary according to the thickness and quality of the food and to consumer taste.
- Use a meat thermometer when roasting meat, or simply press on the roast with a spoon. If it is hard, it is ready; If not, it needs another few minutes cooking.

Advice for cooking with the Grill

- Meat can be grilled even when it is put into the cold oven or into the preheated oven if you wish to change the effect of the cooking.
- We recommend placing the food at the centre of the rack.
- With the Grill function, we recommend that you turn the temperature knob to the maximum value near the symbol  to optimise cooking.



- Foods should be seasoned before cooking. Foods should also be coated with oil or melted butter before cooking.
- Use the tray on the first bottom shelf to collect liquids produced by grilling.
- Grilling processes should never last more than 30 minutes inside the auxiliary oven.

Advice for cooking desserts/pastries and biscuits

- Use dark metal moulds: They help to absorb the heat better.
- The temperature and the cooking time depend on the quality and consistency of the dough.
- To check whether the dessert is cooked right through: At the end of the cooking time, put a toothpick into the highest point of the dessert. If the dough does not stick to the toothpick, the dessert is cooked.
- If the dessert collapses when it comes out of the oven, on the next occasion reduce the set temperature by about 10°C, selecting a longer cooking time if necessary.
- While cooking desserts or vegetables, excessive condensation may form on the glass. In order to avoid this, open the door very carefully a couple of times while cooking.

Advice for defrosting and proving

- Place frozen foods without their packaging in a lidless container on the first shelf of the oven.
- Avoid overlapping the food.
- To defrost meat, use the rack placed on the second level and a tray on the first level. In this way, the liquid from the defrosting food drains away from the food.
- The most delicate parts can be covered with aluminium foil.
- For successful proving, a container of water should be placed in the bottom of the oven.

To save energy

- Stop cooking a few minutes before the time normally used. Cooking will continue for the remaining minutes with the heat which has accumulated inside the oven.
- Reduce any opening of the door to a minimum to avoid heat dispersal.
- Keep the inside of the appliance clean at all times.



3.7 Programmer clock

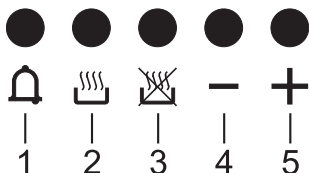

- 1 Minute minder timer key
- 2 Cooking duration key
- 3 End of cooking key
- 4 Value decrease key
- 5 Value increase key

Setting the time

i If the time is not set, the oven will not switch on.

On the first use, or after a power failure, the digits **A 0:00** will be flashing on the appliance's display.

1. Press the keys and at the same time. The dot between the hours and the minutes flashes.
2. The time can be set using the key or . Keep the key pressed in to increase or decrease rapidly.
3. Press the key or wait 5 seconds. The dot between the hours and the minutes stops flashing.
4. The symbol on the display indicates that the appliance is ready to start cooking.

i The programmer clock only controls the main oven and does not control the auxiliary oven.

i Ensure that the programmer clock shows the cooking time symbol otherwise it will not be possible to turn on the oven.

Press the keys and at the same time to reset the programmer clock.



Timed cooking

i Timed cooking is the function which allows a cooking operation to be started and then ended after a specific length of time set by the user.

1. After selecting a cooking function and temperature, press the key . The display will show the digits and the symbol displayed between the hours and the minutes.
2. Use the key or to set the required minutes.
3. Wait approx. 5 seconds without pressing any key in order for the function to activate. The current time and the symbols and will appear on the display.
4. At the end of cooking the heating elements will be deactivated. On the display, symbol turns off, symbol flashes and the buzzer sounds.
5. To turn off the buzzer just press any key of the programmer clock.

6. Press the keys and at the same time to reset the programmer clock.



It is not possible to set a cooking time of more than 10 hours.



After the setting, to display the cooking time left press the key .



To reset the set program, press the keys and at the same time and switch off the oven manually.

Programmed cooking













i Programmed cooking is the function which allows a cooking operation to be started at a set time and then ended after a specific length of time set by the user.

1. Set the cooking time as described in the previous point "Timed cooking".
2. Press the key . The sum of the current time plus the pre-set cooking duration will appear on the display.
3. Use the key or to set the required minutes.



Use

4. Wait approx. 5 seconds without pressing any key in order for the function to activate. The current time and the symbols  and  will appear on the display.
5. At the end of cooking the heating elements will be deactivated. On the display, the symbol  turns off, the symbol  flashes and the buzzer sounds.
6. To turn off the buzzer just press any key of the programmer clock.
7. Press the keys  and  at the same time to reset the programmer clock.

2. Use the key  or  to set the required minutes.
3. Wait approx. 5 seconds without pressing any key to finish setting the minute minder. The current time and the symbols  and  appear on the display.





It is not possible to set a cooking time of more than 24 hours.



After the minute minder timer has been programmed, the display will go back to showing the current time; to display the remaining time, press the key .





After the setting, to display the cooking time left press the key . To display the end of cooking time, press the key .

Minute minder timer



The minute minder timer does not stop the cooking operation but rather informs the user when the set time has run out.



The minute minder timer can be activated at any time.

1. Press the key . The display shows the digits  and the indicator light  flashing between the hours and the minutes.

Adjusting the buzzer volume

The buzzer volume can be set to 3 different levels. When the buzzer is in operation, press the key  to change the setting.

Deleting the set data

Press the keys  and  at the same time to reset the programs set. Then switch off the oven manually if cooking is in progress.



Main oven cooking information table

| Food | Weight (Kg) | Function | Runner position from the bottom | Temperature (°C) | Time (minutes) |
|-----------------|-------------|------------|---------------------------------|------------------|----------------|
| Roast veal | 2 | Circulaire | 2 | 180 - 190 | 90 - 100 |
| Pork | 2 | Circulaire | 2 | 180 - 190 | 70 - 80 |
| Roast beef | 1 | Circulaire | 2 | 200 | 40 - 45 |
| Roast rabbit | 1.5 | Circulaire | 2 | 180 - 190 | 70 - 80 |
| Turkey breast | 3 | Circulaire | 2 | 180 - 190 | 110 - 120 |
| Roast pork neck | 2 - 3 | Circulaire | 2 | 180 - 190 | 170 - 180 |
| Roast chicken | 1.2 | Circulaire | 2 | 180 - 190 | 65 - 70 |
| Salmon trout | 1.2 | Circulaire | 2 | 150 - 160 | 35 - 40 |
| Monkfish | 1.5 | Circulaire | 2 | 160 | 60 - 65 |
| Turbot | 1.5 | Circulaire | 2 | 160 | 45 - 50 |
| Pizza | 1 | Circulaire | 2 | 245 | 8 - 9 |
| Bread | 1 | Circulaire | 2 | 190 - 200 | 25 - 30 |
| Focaccia | 1 | Circulaire | 2 | 180 - 190 | 20 - 25 |
| Bundt cake | 1 | Circulaire | 2 | 160 | 55 - 60 |
| Jam tart | 1 | Circulaire | 2 | 160 | 35 - 40 |
| Ricotta cake | 1 | Circulaire | 2 | 160 - 170 | 55 - 60 |
| Jam tarts | 1 | Circulaire | 2 | 160 | 20 - 25 |
| Paradise cake | 1.2 | Circulaire | 2 | 160 | 55 - 60 |
| Profiteroles | 1.2 | Circulaire | 2 | 180 | 80 - 90 |
| Sponge cake | 1 | Circulaire | 2 | 150 - 160 | 55 - 60 |
| Rice pudding | 1 | Circulaire | 2 | 160 | 55 - 60 |
| Brioche | 0.6 | Circulaire | 2 | 160 | 30 - 35 |

The times indicated in the table do not include preheating times and are provided only as a guide.



Use

Auxiliary oven cooking information table

| Food | Weight (Kg) | Function | Runner position from the bottom | Temperature (°C) | Time (minutes) | |
|-----------------------|-------------|----------|---------------------------------|------------------|-------------------------------|-------------------------------|
| Lasagne | 3 - 4 | Static | 1 | 220 - 230 | 45 - 50 | |
| Pasta bake | 3 - 4 | Static | 1 | 220 - 230 | 45 - 50 | |
| Pizza | 1 | Static | 1 | 245 | 14 - 16 | |
| Savoury spinach pie | 1.2 | Static | 1 | 220 - 230 | 35 - 40 | |
| Focaccia | 0.8 | Static | 1 | 190 - 200 | 18 - 20 | |
| Jam tart | 1 | Static | 1 | 170 - 180 | 35 - 40 | |
| Short pastry | 0.4 | Static | 1 | 170 - 180 | 20 - 25 | |
| Short pastry biscuits | 0.8 | Static | 1 | 170 - 180 | 18 - 20 | |
| Jam tarts | 1.2 | Static | 1 | 170 - 180 | 25 - 30 | |
| Salmon trout | 1.2 | Static | 1 | 150 - 160 | 35 - 40 | |
| Roast rabbit | 1.2 | Static | 1 | 180 - 190 | 70 - 80 | |
| Turkey breast | 1.5 | Static | 1 | 180 - 190 | 80 - 90 | |
| Pork | 1.2 | Static | 1 | 190 - 200 | 80 - 90 | |
| Half roast chicken | 1.2 | Static | 1 | 190 - 200 | 55 - 60 | |
| Sausages | 1.5 | Grill | 2 | 245 | 13 - 15 | |
| | | | | | | |
| | | | | | 1st surface | 2nd surface |
| Pork chops | 1.5 | Grill | 2 | 245 | 15 | 5 |
| Spare ribs | 1.5 | Grill | 2 | 245 | 10 | 10 |
| Bacon | 0.7 | Grill | 2 | 245 | 7 | 8 |
| Pork fillet | 1.5 | Grill | 2 | 245 | 10 | 5 |
| Beef fillet | 1 | Grill | 2 | 245 | 10 | 7 |

The times indicated in the table do not include preheating times and are provided only as a guide.



4 Cleaning and maintenance

4.1 Instructions



Improper use
Risk of damage to surfaces

- Do not use steam jets to clean the appliance.
- Do not use detergents which are abrasive, corrosive or which contain chlorine, ammonia or bleach (e.g. scouring powders, stain removers, etc.).
- Do not use rough or abrasive materials or sharp metal scrapers.
- Do not wash the removable components such as the hob grids, flame-spreader crowns and burner caps in a dishwasher.

4.2 Cleaning the appliance



We recommend the use of cleaning products distributed by the manufacturer.

Recommendations for cleaning the hob

To keep the surfaces in good condition, they should be cleaned regularly after use. Let them cool first.

Cleaning the hob

1. Pour some non-abrasive detergent on a damp cloth and wipe down the surfaces.
2. Rinse thoroughly.
3. Dry with a soft cloth or a microfibre cloth.

Cleaning the hob grids, flame-spreader crowns and burner caps

1. Remove the components from the hob.
2. Clean it with warm water and non-abrasive detergent. Make sure to remove any encrustations.
3. Dry thoroughly with a soft cloth or a microfibre cloth.
4. Replace the components on the hob.



The continuous contact between the grids and the flame can cause modifications to the enamel over time in those parts exposed to heat. This is a completely natural phenomenon which has no effect on the operation of this component.

Cleaning the igniters and thermocouples

- If necessary, clean the igniters and thermocouples with a damp cloth.
- If there is any dry residue, remove it with a toothpick or needle.

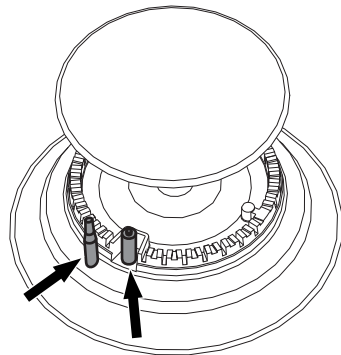



Cleaning and maintenance

Recommendations for cleaning the oven compartment

In order to keep your oven in the best possible condition, clean it regularly after letting it cool down.

Avoid letting food residue dry inside the oven compartment, as this could damage the enamel.

Take out all removable parts before cleaning.

For easier cleaning, we recommend removing:

- The door
- The rack/tray support frames
- The seal



In the event you are using specific cleaning products, we recommend running the oven at maximum temperature for 15-20 minutes in order to eliminate any residue.

4.3 Removing the door

For easier cleaning, the door can be removed and placed on a canvas.

To remove the door proceed as follows:

1. Open the door completely and insert two pins into the holes on the hinges indicated in the figure.

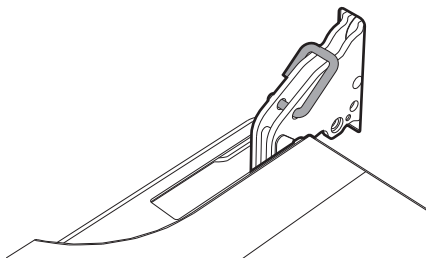

2. Grasp the door on both sides with both hands, lift it forming an angle of around 30° and remove it.

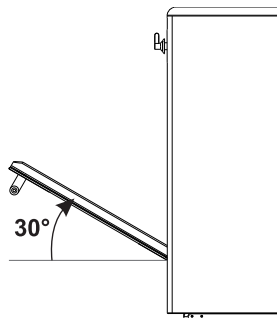

3. To reassemble the door, put the hinges in the relevant slots on the front of the oven, making sure that the grooved sections **A** are resting completely in the slots. Lower the door and once it is in place remove the pins from the holes in the hinges.

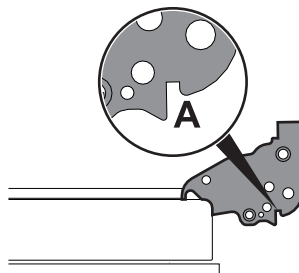

4.4 Cleaning the door glazing

The glass in the door should always be kept thoroughly clean. Use absorbent kitchen roll. In case of stubborn dirt, wash with a damp sponge and an ordinary detergent.



We recommend the use of cleaning products distributed by the manufacturer.

Cleaning and maintenance



1. Remove the internal glass pane by pulling the rear part gently upwards, following the movement indicated by the arrows (1).
2. Then, pull the front part upwards (2). In this way, the 4 pins attached to the glass detach from their housings in the oven door.

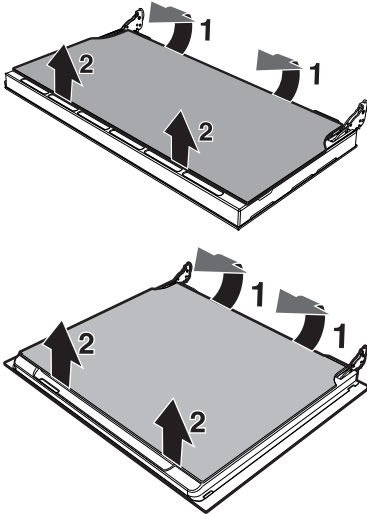

3. Remove the intermediate glass pane by lifting it upwards.

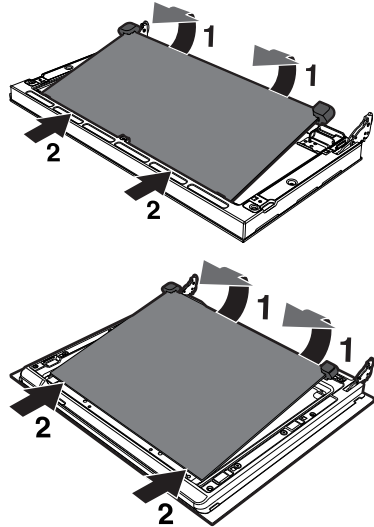

4. Clean the external glass pane and the panes previously removed. Use absorbent kitchen roll. In case of stubborn dirt, wash with a damp sponge and neutral detergent.

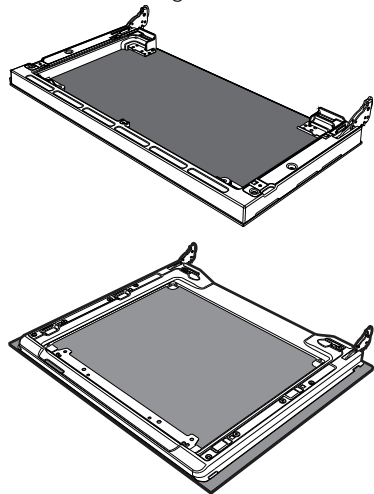

EN



Cleaning and maintenance

5. Refit the panes in the reverse order in which they were removed.
6. Reposition the internal glass pane. Take care to centre and insert the 4 pins into their housings in the oven door by applying slight pressure.

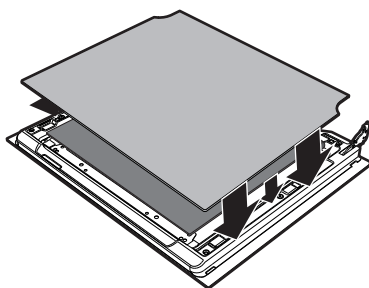
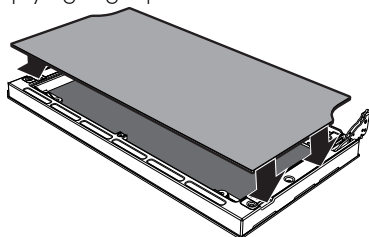

Removing rack/tray support frames

Removing the rack/tray support frames enables the sides to be cleaned more easily.

To remove the rack/tray support frames, pull the frame towards the inside of the oven to unhook it from its groove **A**, then slide it out of the seats at the back **B**.

When cleaning is complete, repeat the above procedures to put the rack/tray support frames back in.

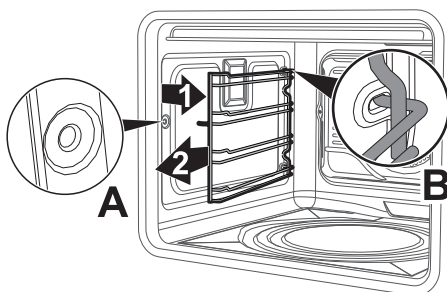

4.5 Extraordinary maintenance

Removing and installing the seal

To remove the seal:

- Unhook the clips in the 4 corners then pull the seal outwards.

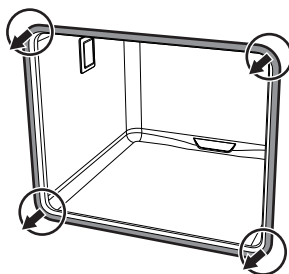

To refit the seal:

- Hook the clips in the 4 corners onto the seal.

Seal maintenance tips

The seal should be soft and elastic.

- To keep the seal clean, use a non-abrasive sponge and lukewarm water to wash it.



Replacing the oven light bulb



Live parts
Danger of electrocution

- Disconnect the appliance from the power supply.



The oven is fitted with a 40W light bulb.

1. Completely remove all accessories from inside the oven.
2. Remove the rack/tray support frames.
3. Remove the bulb cover using a tool (e.g. a screwdriver).



Pay attention not to scratch the oven compartment enamel.

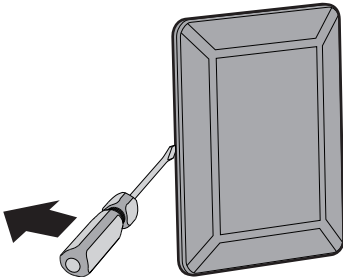

4. Slide out and remove the lamp.

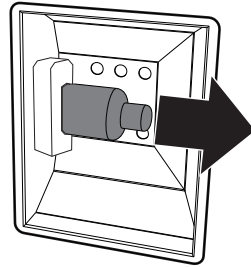

Do not touch the halogen lamp directly with your fingers, but wrap it in insulating material.

5. Fit the new light bulb.
6. Refit the cover. Ensure the moulded part of the glass (A) is facing the door.

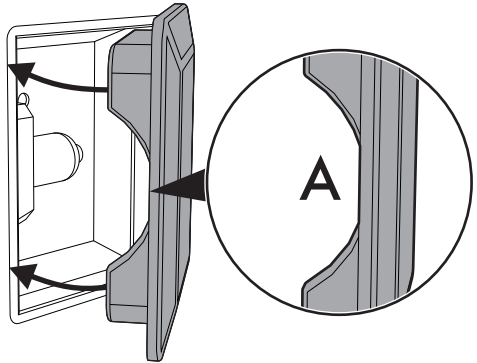

7. Press the cover completely down so that it attaches perfectly to the bulb support.



Installation

5 Installation

5.1 Gas connection



**Gas leak
Danger of explosion**

- After carrying out any operation, check that the tightening torque of gas connections is between 10 Nm and 15 Nm.
- If required, use a pressure regulator that complies with current regulations.
- At the end of the installation, check for any leaks with a soapy solution, never with a flame.
- Installation using a hose must be carried out so that the length of the hose does not exceed 2 metres when fully extended for steel hoses and 1.5 metres for rubber hoses.
- The hoses should not come into contact with moving parts and should not be crushed in any way.



For installation in the UK, please refer to the leaflet "Local installation specification for UK gas appliances", supplied.

Connection with a rubber hose

Verify that all following conditions are met:

- the hose is fixed to the hose connection with safety clamps;
- no part of the hose is in contact with hot walls (max. 50 °C);
- the hose is not under traction or tension and has no kinks or twists;
- the hose is not in contact with sharp objects or sharp corners;
- if the hose is not perfectly airtight and leaks gas, do not try to repair it; replace it with a new hose.
- verify that the hose is not past its expiry date (serigraphed on the hose itself).

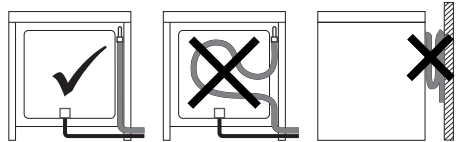

Make the connection to the gas mains using a rubber hose whose specifications comply with current standards (verify that the reference standard is stamped on the hose).

General information

Connection to the gas mains can be made using a continuous wall steel hose in compliance with the guidelines established by the standards in force.

For supplying it with other types of gas, see chapter "5.2 Adaptation to different types of gas". The gas inlet connection is threaded 1/2" external gas (ISO 228-1).



Carefully screw the hose connector **3** to the appliance's gas connector **(1)** ($\frac{1}{2}$ " thread ISO 228-1), placing the seal **(2)** between them. The hose connector **(4)** can also be screwed to the hose connector **(3)**, depending on the diameter of the gas hose used. After tightening the hose connector(s), push the gas hose **(6)** onto the hose connector and secure it with the clamp **(5)**, which must meet applicable standards.

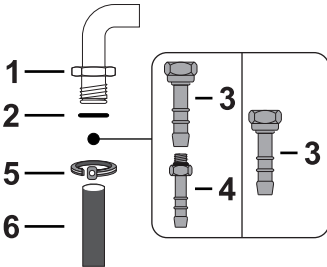

Connection using a rubber hose complying with current standards is only permitted if the hose can be inspected along its entire length.



The inside diameter of the hose must be 8 mm for LPG and 13 mm for Natural gas and Town gas.

Connection with a steel hose

Make the connection to the gas mains using a continuous wall steel hose whose specifications comply with the applicable standard.

Carefully screw the connector **(3)** to the gas connector **(1)** of the appliance, placing the seal **(2)** between them.

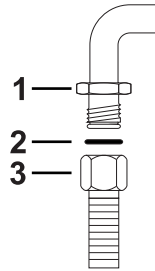

Connection with a steel hose with bayonet fitting

Carry out the connection to the gas mains using a steel hose with bayonet fitting compliant with B.S. 669. Apply insulating material to the thread of the gas hose connector **(4)** and then tighten the adapter **(3)**. Screw the assembly to the movable connector **(1)** of the appliance, placing the supplied seal **(2)** between them.

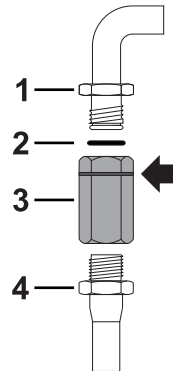



Installation

Connection with a steel hose with conical fitting

Make the connection to the gas mains using a continuous wall steel hose whose specifications comply with the applicable standard.

Carefully screw the hose connector **3** to the appliance's gas connector **(1)** ($\frac{1}{2}$ " thread ISO 228-1), placing the supplied seal **(2)** between them. Apply insulating material to the thread of connector **(3)**, then tighten the steel hose **(4)** to the connector **(3)**.

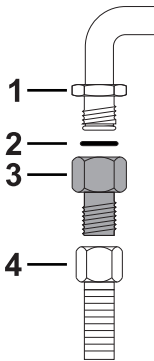

Connection to LPG

Use a pressure regulator and make the connection on the gas cylinder following the guidelines set out in the standards in force.

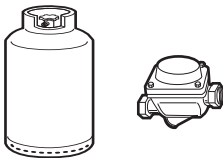

The supply pressure must comply with the values indicated in the table in "Gas types and Countries".

Room ventilation

The appliance should be installed in rooms that have a permanent air supply in accordance with the standards in force. The room where the appliance is installed must have enough air flow for the regular combustion of gas and the necessary air change in the room itself. The air vents, protected by grilles, must be the right size to comply with current regulations and positioned so that no part of them is obstructed, not even partially.

The room must be kept adequately ventilated in order to eliminate the heat and humidity produced by cooking: In particular, after prolonged use, you are recommended to open a window or to increase the speed of any fans.

Extraction of the combustion products

The combustion products may be extracted by means of hoods connected to a natural draught chimney whose efficiency is certain or via forced extraction. An efficient extraction system requires precision planning by a specialist qualified in this area and must comply with the positions and clearances indicated by the applicable standards.



When the job is complete, the installer must issue a certificate of conformity.

5.2 Adaptation to different types of gas

In case of operation with other types of gas, the burner nozzles must be changed and the minimum flame adjusted on the gas taps.

EN

Replacing nozzles

1. Remove the grids, burner caps and flame-spreader crowns to access the burner casings.
2. Replace the nozzles using a 7 mm socket wrench according to the gas to be used (see Burner and nozzle characteristics tables).

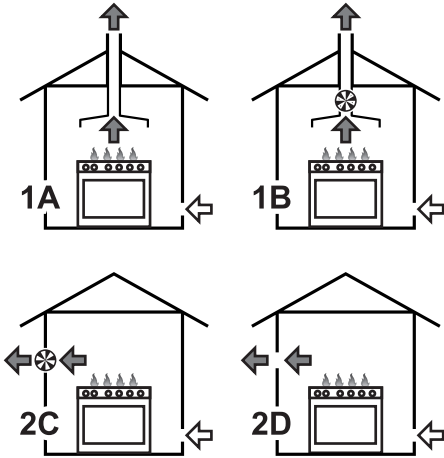

- 1 Extraction using a hood
2 Extraction without a hood

- A Single natural draught chimney
B Single chimney with extractor fan
C Directly outdoors with wall- or window-mounted extractor fan
D Directly outdoors through wall

- ↔ Air
← Combustion products
⊗ Extractor fan

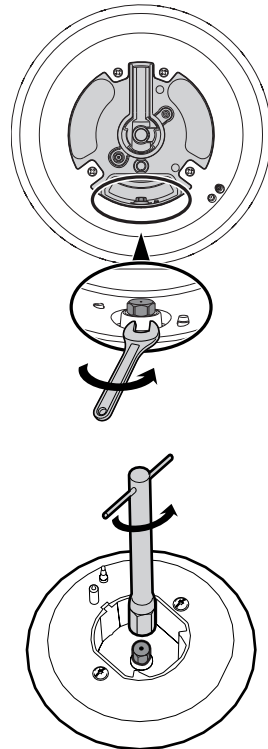

3. Reposition the burners in their correct seats.



Installation

Adjusting the minimum setting for natural or town gas

Light the burner and turn it to the minimum position. Extract the gas tap knob and turn the adjustment screw next to the tap rod (depending on the model) until the correct minimum flame is achieved.

Refit the knob and verify that the burner flame is stable. Turn the knob rapidly from the maximum to the minimum setting: The flame should not go out. Repeat the operation on all gas taps.

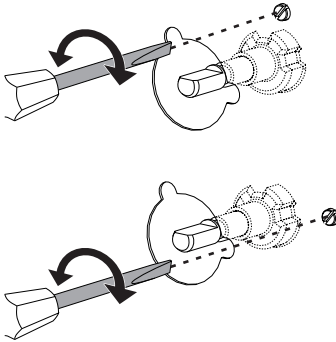

Adjusting the minimum setting for LPG

Tighten the screw located at the side of the tap rod clockwise all the way.



Following adjustment to a gas other than the one originally set in the factory, replace the gas setting label on the appliance with the one corresponding to the new gas. The label is inserted inside the nozzle pack (where present).

Lubricating the gas taps

Over time the gas taps may become difficult to turn and get blocked. Clean them internally and replace the lubrication grease.



Lubrication of the gas taps should be performed by a specialised technician.



Gas types and Countries

| Gas types | | IT | GB-IE | FR-BE | DE | AT | NL | ES | PT | SE | RU | DK | PL | FI-NO |
|-----------------------------|---------------|----|-------|-------|----|----|----|----|----|----|----|----|----|-------|
| 1 Natural Gas G20 | | | | | | | | | | | | | | |
| G20 | 20 mbar | • | • | | • | • | • | • | • | • | • | • | • | • |
| G20/25 | 20/25 mbar | | | • | | | | | | | | | | |
| 2 Natural Gas G25.3 | | | | | | | | | | | | | | |
| G25.3 | 25 mbar | | | | | | • | | | | | | | |
| 3 Natural Gas G25 | | | | | | | | | | | | | | |
| G25 | 20 mbar | | | | • | | | | | | | | | |
| 4 Natural Gas G2.350 | | | | | | | | | | | | | | |
| G2.350 | 13 mbar | | | | | | | | | | | | • | |
| 5 LPG G30/31 | | | | | | | | | | | | | | |
| G30/31 | 28-30/37 mbar | • | • | • | | | | • | • | | • | | | |
| G30/31 | 30/30 mbar | | | | | | • | | | • | | • | | • |
| 6 LPG G30/31 | | | | | | | | | | | | | | |
| G30/31 | 37 mbar | | | | | | | | | | | | • | |
| 7 LPG G30/31 | | | | | | | | | | | | | | |
| G30/31 | 50 mbar | | | | • | • | | | | | | | | |
| 8 Town gas G110 | | | | | | | | | | | | | | |
| G110 | 8 mbar | • | | | | | | | | • | | • | | |

EN

Burner and nozzle characteristics tables

| | | | | |
|---------------------------------|--|------------|-----------|------------|
| 1 Natural Gas G20 | | AUX | SR | UR2 |
| Rated heating capacity (kW) | | 1.0 | 1.8 | 4.2 |
| Nozzle diameter (1/100 mm) | | 72 | 97 | 155 |
| Pre-chamber (printed on nozzle) | | (X) | (Z) | (H3) |
| Reduced flow rate (W) | | 400 | 500 | 1200 |
| 2 Natural Gas G25.3 | | AUX | SR | UR2 |
| Rated heating capacity (kW) | | 1.0 | 1.8 | 4.2 |
| Nozzle diameter (1/100 mm) | | 72 | 94 | 143 |
| Pre-chamber (printed on nozzle) | | (F1) | (Y) | (F2) |
| Reduced flow rate (W) | | 400 | 500 | 1200 |
| 3 Natural Gas G25 | | AUX | SR | UR2 |
| Rated heating capacity (kW) | | 1.0 | 1.8 | 4.1 |
| Nozzle diameter (1/100 mm) | | 77 | 100 | 165 |
| Pre-chamber (printed on nozzle) | | (F1) | (Y) | (H3) |
| Reduced flow rate (W) | | 400 | 500 | 1200 |



Installation

| 4 Natural Gas G2.350 | AUX | SR | UR2 |
|---------------------------------|------|-----|------|
| Rated heating capacity (kW) | 1.0 | 1.8 | 4.0 |
| Nozzle diameter (1/100 mm) | 94 | 120 | 190 |
| Pre-chamber (printed on nozzle) | (Y) | (Y) | (F3) |
| Reduced flow rate (W) | 400 | 500 | 1200 |
| 5 LPG G30/31 | AUX | SR | UR2 |
| Rated heating capacity (kW) | 1.0 | 1.8 | 4.0 |
| Nozzle diameter (1/100 mm) | 50 | 65 | 100 |
| Pre-chamber (printed on nozzle) | - | - | - |
| Reduced flow rate (W) | 400 | 500 | 1300 |
| Rated flow rate G30 (g/h) | 73 | 131 | 291 |
| Rated flow rate G31 (g/h) | 71 | 129 | 286 |
| 6 LPG G30/31 | AUX | SR | UR2 |
| Rated heating capacity (kW) | 1.1 | 1.9 | 4.2 |
| Nozzle diameter (1/100 mm) | 50 | 65 | 95 |
| Pre-chamber (printed on nozzle) | - | - | - |
| Reduced flow rate (W) | 450 | 550 | 1500 |
| Rated flow rate G30 (g/h) | 80 | 138 | 305 |
| Rated flow rate G31 (g/h) | 79 | 136 | 300 |
| 7 LPG G30/31 | AUX | SR | UR2 |
| Rated heating capacity (kW) | 1.0 | 1.8 | 4.1 |
| Nozzle diameter (1/100 mm) | 43 | 58 | 80 |
| Pre-chamber (printed on nozzle) | (H2) | (M) | (F4) |
| Reduced flow rate (W) | 400 | 500 | 1500 |
| Rated flow rate G30 (g/h) | 73 | 131 | 298 |
| Rated flow rate G31 (g/h) | 71 | 129 | 293 |
| 8 Town gas G110 | AUX | SR | UR2 |
| Rated heating capacity (kW) | 1.0 | 1.8 | 3.4 |
| Nozzle diameter (1/100 mm) | 145 | 185 | 340 |
| Pre-chamber (printed on nozzle) | /8 | /2 | 0190 |
| Reduced flow rate (W) | 400 | 500 | 1200 |

The nozzles not provided are available at Authorised Service Centres.



5.3 Electrical connection



**Power voltage
Danger of electrocution**

- Have the electrical connection performed by authorised technical personnel.
- Use personal protective equipment.
- The appliance must be connected to earth in compliance with electrical system safety standards.
- Disconnect the mains supply.
- Do not pull the cable to remove the plug.
- Use cables withstanding a temperature of at least 90°C.
- The tightening torque of the screws of the terminal board conductors must be 1.5 - 2 Nm.

General information

Check the grid characteristics against the data indicated on the plate.
The identification plate bearing the technical data, serial number and brand name is visibly positioned on the appliance. Do not remove this plate for any reason. Perform the ground connection using a wire that is 20 mm longer than the other wires.

The appliance can work in the following modes:

- **220-240 V 1N~**

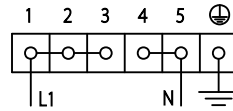

3 x 2.5 mm² three-core cable.

- **380-415 V 2N~**

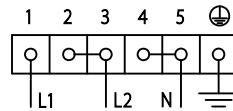

4 x 1.5 mm² four-core cable.

- **380-415 V 3N~**

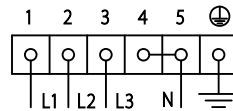

5 x 1.5 mm² five-core cable.



The values indicated above refer to the cross-section of the internal conductor.



The aforementioned power cables are sized taking into account the coincidence factor (in compliance with standard EN 60335-2-6).



Installation

Fixed connection

Fit the power line with an all-pole disconnection switch, with a clearance between its contacts that allows the complete disconnection as per the overvoltage category III, in compliance with the installation regulations.

Access to the terminal board

To connect the power supply cable, you must access the terminal board on the rear casing:

1. Remove the screws fastening the plate to the rear casing.

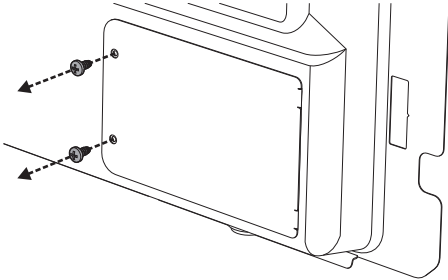

2. Gently rotate the plate and remove it from its seat.

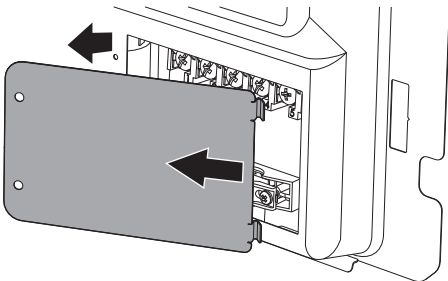

3. Proceed with installation of the power supply cable.

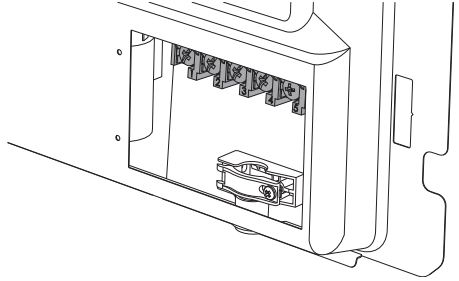

It is recommended to slacken off the cable clamp screw before installing the power supply cable.

4. When you have finished, reposition the plate on the rear casing and fasten it in place with the previously removed screws.

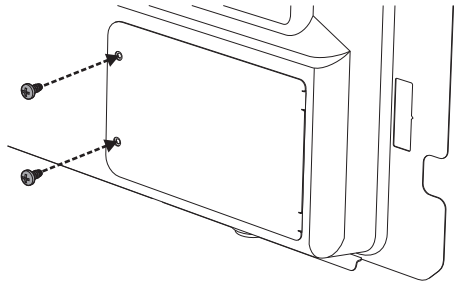



5.4 Positioning



**Heavy appliance
Crushing hazard**

- Position the appliance into the cabinet cutout with the help of a second person.



**Pressure on the open door
Risk of damage to the appliance**

- Never use the oven door to lever the appliance into place when fitting.
- Avoid exerting too much pressure on the oven door when open.



**Heat production during appliance operation
Risk of fire**

- Veneers, adhesives or plastic coatings on adjacent furniture should be temperature-resistant (no less than 90°C).

General information

This appliance may be installed next to walls, one of which must be higher than the worktop, at a minimum distance of 50 mm from the side of the appliance, as shown in figures A and C relative to the installation classes.

Any wall units positioned above the worktop must be at a minimum distance of at least 750 mm. If a hood is installed above the hob, refer to the hood instruction manual to ensure the correct clearance is left.

Depending on the type of installation, this appliance belongs to classes:

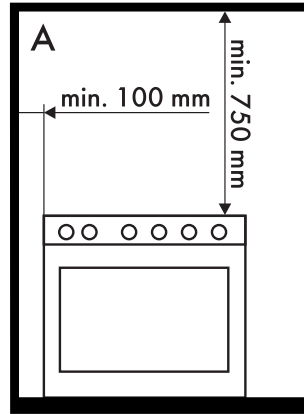

A - Class 1

(Free-standing appliance)

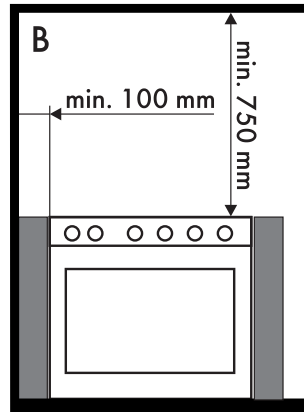

B - Class 2 subclass 1

(Built-in appliance)



Installation

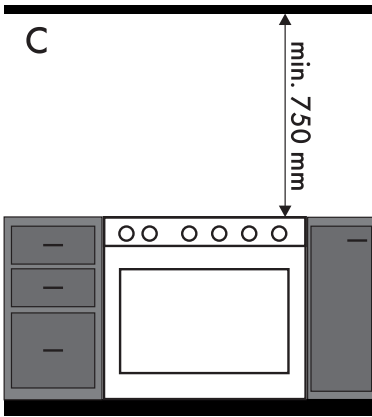

**C - Class 2 subclass 1
(Built-in appliance)**



The appliance must be installed by a qualified technician and according to the regulations in force.

Assembling the upstand



The upstand provided is an integral part of the product; it must be fastened to the appliance prior to installation.

The upstand must always be positioned and secured correctly on the appliance.

1. Loosen the 3 screws on the back of the top (A) and unscrew the 2 screws (B) on the side part of the upstand.

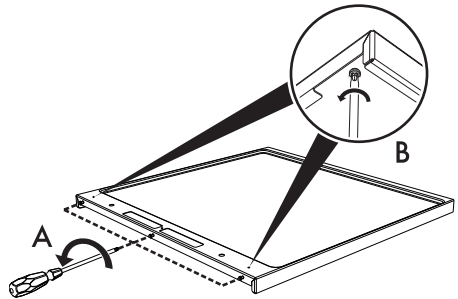

2. Place the upstand on the top. Align the 3 bottom slots of the upstand with the 3 screws on the back of the top that were previously loosened.
3. Tighten the 3 screws on the back of the hob (A) and tighten the 2 screws under the top (B) to secure the upstand.

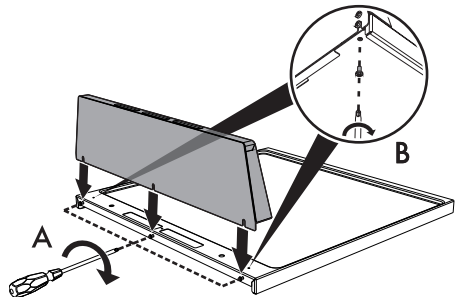



Mounting the toe skirt

i The toe skirt provided is an integral part of the product; it must be fastened to the appliance prior to installation.

The toe skirt must always be positioned and secured correctly on the appliance.

1. Place the toe skirt in the front bottom part of the appliance.
2. Screw the two side screws to fasten the toe skirt to the appliance.
3. Cover the holes of the toe skirt with the plugs provided.

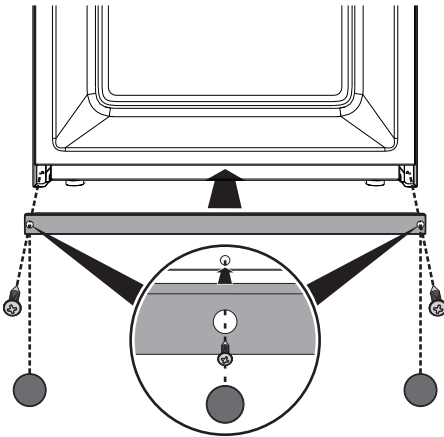

Positioning and levelling the appliance

After making the electrical and/or gas connections, properly level the appliance on the floor to ensure better stability. Screw or unscrew the bottom part of the foot until the appliance is stable and level on the floor.

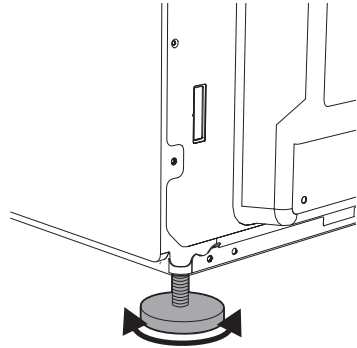



5.5 Instructions for the installer

- The plug must be accessible after installation. Do not bend or trap the power cable.
- The appliance must be installed according to the installation diagrams.
- Do not try to unscrew or force the threaded elbow of the fitting. You may damage this part of the appliance, which may void the manufacturer's warranty.
- Use soap and water to check for gas leaks on all connections. DO NOT use naked flames when looking for leaks.
- Turn on all the burners separately and at then all together to make sure that the gas valve, burner and ignition are working properly.
- Turn the burner knobs to the minimum position and check that the flame is stable for each individual burner and all the burners together.
- If the appliance does not work correctly after having carried out all the checks, contact your local Authorised Service Centre.
- Once the appliance has been installed, please explain to the user how to use it correctly.