

1. INSTRUCTIONS FOR USE	4
2. SAFETY PRECAUTIONS	6
3. ENVIRONMENTAL CARE	8
3.1 Our environmental care	8
3.2 Your environmental care	8
4. GET TO KNOW YOUR APPLIANCE	9
4.1 Description of the controls on the front panel	9
5. AVAILABLE ACCESSORIES	10
5.1 Using the rack or tray	10
5.2 Using the support rack	11
5.3 Using the reduction pan stands	11
5.4 Using the rotisserie rod (on some models only)	11
6. USING THE COOKING HOB	12
6.1 General warnings and advice	12
6.2 Lighting the hob burners	12
6.3 Practical hints for using the hob burners	12
6.4 Pan diameters	13
6.5 Glass lid (on some models only)	13
7. USING THE OVEN	14
7.1 Before using the appliance	14
7.2 Oven runners	14
7.3 Storage compartment (on some models only)	14
7.4 Cooling fan system (on some models only)	14
7.5 Internal light	14
7.6 General warnings and advice for use	15
7.7 Electronic programmer	16
8. COOKING WITH THE OVEN	18
8.1 Cooking advice and instructions	19
8.2 Cooking process information table	20
9. CLEANING AND MAINTENANCE	21
9.1 Cleaning stainless steel	21
9.2 Ordinary daily cleaning	21
9.3 Food stains or residues	21
9.4 Cleaning the cooking hob parts	21
9.5 Cleaning the oven	23
9.6 VAPOR CLEAN: assisted oven cleaning (on some models only)	24
10. EXTRAORDINARY MAINTENANCE	26
10.1 Replacing the light bulb	26
10.2 Removing the door	26
10.3 Removing the door seal (not on pyrolytic models)	27
10.4 Removing the internal glass panels	27
11. INSTALLATION	28
11.1 Minimum clearance to combustible surfaces	28
11.2 Combustion gas discharge	29
11.3 Gas connection	29
11.4 Room ventilation	29
11.5 Extraction of the combustion products	30
11.6 Electrical connection	30
11.7 Positioning the skirt (on some models only)	32
11.8 Positioning and levelling the appliance	32
11.9 Wall mounting brackets (where present)	32
11.10 Wall fixing	33
12. ADAPTATION TO DIFFERENT TYPES OF GAS	34

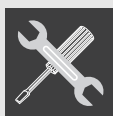

INSTRUCTIONS FOR THE USER: these instructions contain user recommendations, a description of the controls and the correct procedures for cleaning and maintenance of the appliance.



INSTRUCTIONS FOR THE INSTALLER: these are intended for the authorised person who must install the appliance, set it functioning and carry out an inspection test.



Further information about the products can be found at www.smeg.com



1. INSTRUCTIONS FOR USE



This manual is an integral part of the appliance. It must be kept in its entirety and in an accessible place for the whole working life of the appliance. We urge you to read this manual and all the information it contains carefully before using the appliance. Installation must be carried out by qualified personnel in accordance with the regulations in force. This appliance is intended for domestic use and conforms to the EC directives currently in force. The appliance has been built to carry out the following functions: **cooking and heating up food**; all other uses are considered unsuitable.



These instructions are valid only for the destination countries whose identifying symbols are included on the cover of this manual.



Never obstruct the openings and slits provided for ventilation and heat dispersal; this may cause malfunctions.



DO NOT USE THIS APPLIANCE AS A SPACE HEATER.



The identification plate with technical data, serial number and brand name is located in an exposed position either in the drawer (where present) or on the back of the appliance. A copy of the identification plate is included in the booklet. It should be applied to an adjacent surface, ie. a cupboard.



Before the appliance is put into operation, all labels and protective films applied on external surfaces must be removed.



Do not use metallic sponges or sharp scrapers: they will damage the surfaces. Use normal non-abrasive products and a wooden or plastic tool if necessary. Rinse thoroughly and dry using a soft cloth. Do not allow residues of sugary foods (such as jam) to set for too long, as this may spoil the enamel on the inside the oven.



Do not use plastic kitchenware or containers. The high temperatures inside the oven could melt the plastic, damaging the appliance.



Always check that the control knobs are in the “zero” (off) position when you finish using the appliance.



Do not use sealed tins or containers in the appliance. Overpressure may occur inside the containers during cooking, creating a danger of explosion.



Do not cover the bottom of the oven with aluminium or tinfoil sheets during cooking and do not place pans or trays on it to avoid damage to the enamelled surface.



Never place saucepans with bases which are not perfectly flat and smooth on the hob. Unstable cookware can lead to scalding.



Do not rest any weight or sit on the open door of the appliance. Excessive weight may jeopardise its stability.



The appliance becomes very hot during use. Suitable heat-proof gloves should be worn for all operations.



Do not use the hob if pyrolysis is taking place inside the oven (where present).



General instructions

EN



If you intend to go away for a prolonged period of time, close the mains gas tap or the gas cylinder tap.



Take care that no objects are stuck in the door of the oven.



Do not open the storage compartment (where present) when the oven is on and still hot. The temperatures inside it may be very high.



If the surfaces are still very hot during cooking, do not pour water directly onto the trays. The steam could cause severe burns and damage enamelled surfaces.



All cooking operations must take place with the door closed. The dissipation of heat may cause hazards.



DO NOT USE OR STORE FLAMMABLE MATERIALS IN THE APPLIANCE STORAGE DRAWER OR NEAR THIS APPLIANCE



DO NOT PLACE ARTICLES ON OR AGAINST THIS APPLIANCE.



Not suitable for use with aftermarket lids or covers.



The manufacturer declines all responsibility for damage to persons or things caused by non-observance of the above prescriptions or by interference with any part of the appliance or by the use of non-original spare parts.



2. SAFETY PRECAUTIONS

Consult the installation instructions for safety standards on electrical or gas appliances and for ventilation functions. In your interests and for your safety the law requires that the installation and servicing of all electrical and gas appliances be carried out by qualified personnel in accordance with the standards in force. Our approved installers guarantee a satisfactory job.

Gas or electrical appliances must always be uninstalled by suitably skilled people.



Before connecting the appliance to the power grid, check the data on the plate against the data for the grid itself.



If the appliance is installed on a raised platform, secure it using suitable fastening systems.



Before carrying out installation/maintenance work, make sure that the appliance is disconnected from the power grid.



If cooking appliances are installed in motor vehicles (for example, camper vans, caravans etc.), they must only be used when the vehicle is stationary.



Where this appliance is installed in marine craft or in caravans, it shall **not** be used as a space heater.



Install the appliance so that when opening the drawers or doors of units positioned at the level of the hob there is no possibility of making contact with pans positioned on top of it.



Immediately after installation, carry out a quick test on the appliance following the instructions provided later in this manual. Should the appliance not function, disconnect it from the power supply and call the nearest technical assistance centre.



The plug to be connected to the power supply cable and its socket must be of the same type and conform to the standards in force. The socket must be accessible after the appliance has been installed. **Never disconnect the plug by pulling on the cable.**



If this cooking range is to be connected to a new or upgraded electrical installation, then it must be connected by a supply cord fitted with:

- An appropriate rated plug that is compatible with the socket-outlet fitted to the final sub-circuit in the fixed wiring that supplies this cooker.
- An appropriate rated installation male connector that is compatible with the installation female connector fitted to the final sub-circuit in the fixed wiring that supplies the cooker.



If the power supply cable is damaged, contact the technical assistance centre immediately and they will replace it.



- The appliance must be connected to earth in compliance with electrical system safety standards.
- If the electrical supply is restricted, means of all-pole disconnection must be accessible and incorporated in the fixed wiring in accordance with the wiring rules.



During use the appliance and its accessible parts become very hot. Care should be taken to avoid touching heating elements inside the oven. Young children should be supervised to ensure that they do not play with the appliance.



Accessible parts will become hot when in use. To avoid burns young children should be kept away.



Never put inflammable objects in the oven: they could be accidentally ignited and cause fires.



General instructions

EN



The appliance is intended for use by adults. Do not allow children to go near it or play with it.



This appliance is not intended for use by persons (including children) with reduced physical sensory or mental capabilities, or lack of experience and knowledge, unless they have been given supervised or instruction concerning use of the appliance by a responsible person for their safety.



Never attempt to repair the appliance. All repairs must be carried out by an authorised technician or at an authorised service centre. The improper use of tools can cause hazards.



DO NOT MODIFY THIS APPLIANCE.



Do not use or store flammable materials in the appliance storage drawer or near this appliance.



This appliance is not intended to be operated by means of external timer or separate remote control system.

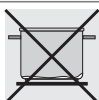

Be aware of how rapidly the cooking zones heat up. Do not place empty saucepans on the heat. Danger of overheating.



- Fats and oils can catch fire if they overheat. You are therefore recommended not to leave the appliance unattended while preparing foods containing oils or fats. If fats or oils catch fire, never put water on them. Place the lid on the saucepan and turn off the cooking zone.
- Danger of fire – Do not store items on the cooking surface.
- Warning – Unattended cooking on a hob with fat or oil can be dangerous and may result in a fire.



Take care when using additional electrical appliances in the kitchen (e.g. blender, toaster etc.). Connection cables must not come into contact with hot cooking zones.



- Do not use harsh abrasive cleaners or sharp metal scrapers to clean the oven glass door since they can scratch the surface, which may result in shattering of the glass.
- If this appliance is installed on a base, measures must be taken to prevent the appliance from slipping from the base.
- This appliance must not be installed behind a decorative door.
- CAUTION – The cooking process has to be supervised. A short term cooking process has to be supervised continuously.



Do not use a steam cleaner to clean this appliance. The steam could reach the electronics, damaging them and causing short-circuits.



DO NOT SPRAY AEROSOLS IN THE VICINITY OF THIS APPLIANCE WHILE IT IS IN OPERATION. Do not use spray products while the appliance is still hot. The gases contained in spray cans may catch fire.



All servicing and maintenance are to be completed by the manufacturer's authorised personnel only.



The manufacturer declines all responsibility for damage to persons or things caused by non-observance of the above prescriptions or by interference with any part of the appliance or by the use of non-original spare parts.



3. ENVIRONMENTAL CARE

3.1 Our environmental care

Adequate differentiated collection for the subsequent forwarding of the decommissioned product to recycling, processing and ecologically compatible disposal contributes to avoiding possible negative effects on the environment and on health, and promotes recycling of the appliance's constituent materials. Illicit disposal of the product by the user will lead to the application of administrative sanctions.

The product does not contain substances in quantities sufficient to be considered hazardous to health and the environment, in accordance with current European directives.

3.2 Your environmental care

Our appliances are packed in non-polluting materials, which are therefore compatible with the environment and recyclable. Please help by disposing of the packaging correctly. You can obtain the addresses of collection, recycling and disposal centres from your retailer or from the competent local organisations.



Do not discard the packaging or any part of it, or leave it unattended. It can constitute a suffocation hazard for children, especially the plastic bags.

Your old appliance also needs to be disposed of correctly.

Important: hand over your appliance to the local agency authorised for the collection of household appliances no longer in use. Correct disposal enables intelligent recovery of valuable materials.

Before disposing of your appliance it is important to remove doors and leave shelves in the same position as for use, to ensure that children cannot accidentally become trapped inside during play. It is also necessary to cut the connecting cable to the power supply network, removing it along with the plug.



4. GET TO KNOW YOUR APPLIANCE

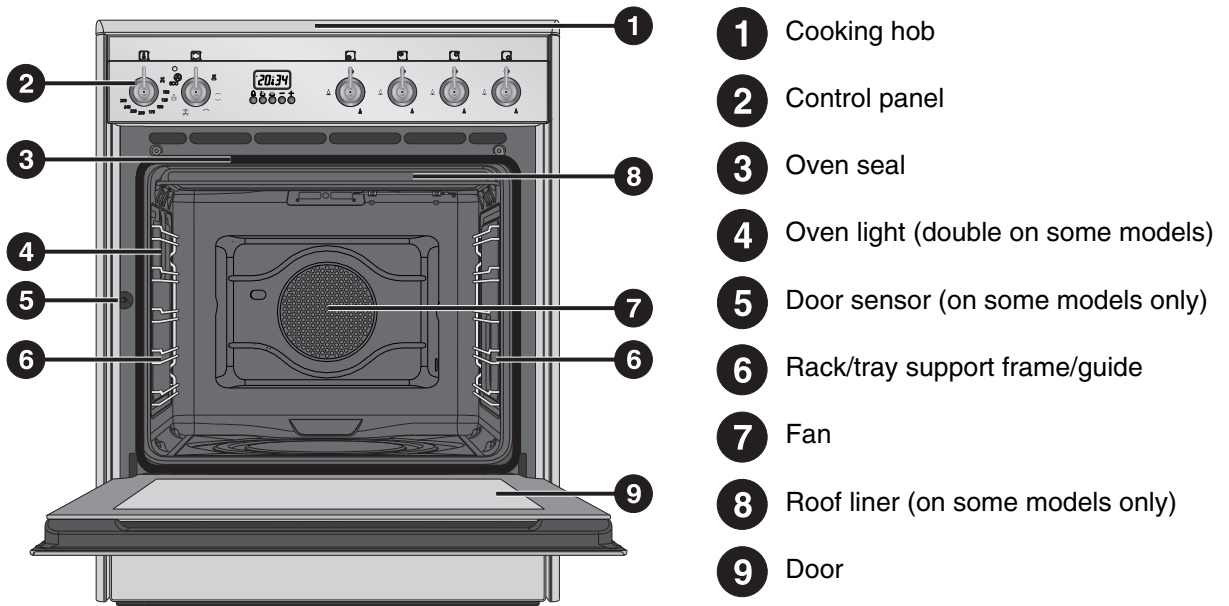

4.1 Description of the controls on the front panel

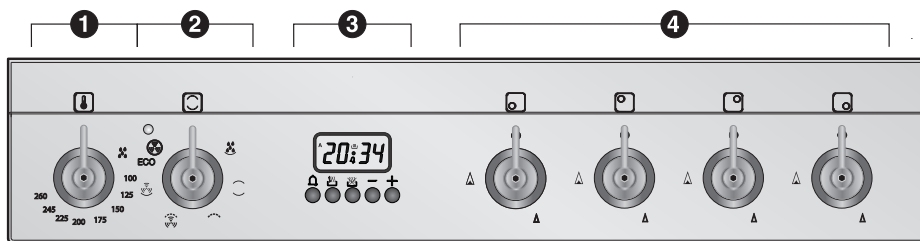

4.1.1 Temperature selection knob

- 1** The cooking temperature is selected by turning the knob clockwise to the required setting, between 50° and 260°C. The indicator light comes on to indicate that the oven is heating up. When this light goes out, the preset heating temperature has been reached. When the light flashes regularly, it means that the temperature inside the oven is kept steady on the set level.



4.1.2 Function selection knob

- 2** The oven's various functions are suitable for different cooking modes. After selecting the required function, set the cooking temperature using the thermostat knob. For more information on the cooking functions, see: "8. COOKING WITH THE OVEN".



4.1.3 Programming clock

- 3** The programming clock can be used to display the current time or to set a timer or a programmed cooking operation.



The timer does not stop the cooking operation. It only warns the user that the preset number of minutes have passed.

4.1.4 Hob burners control knob

- 4** To light the flame, press the knob and turn it anti-clockwise to the maximum flame symbol (▲). To adjust the flame, turn the knob to the zone between the maximum (▲) and the minimum (▲) settings. To turn off the burner, turn the knob to the ● position. (The adjacent symbol indicates the front left burner).





5. AVAILABLE ACCESSORIES



NOTE:

Some models are not provided with all accessories.

Rack: useful for holding cooking containers.

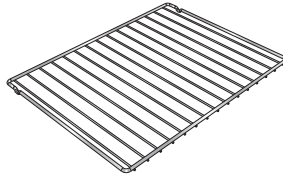

Tray rack: to be placed over the top of the oven tray; for cooking foods which may drip.



Oven tray: useful for collecting fat from foods placed on the rack above.



Deep oven tray: for baking cakes, pizza and oven-baked desserts.

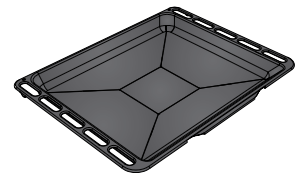

Reduction pan stand: useful when using small pans.

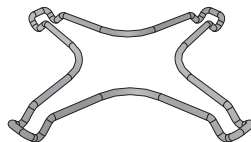

WOK reduction: useful when using a wok.

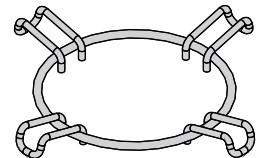

The oven accessories intended to come into contact with food are made of materials that comply with the provisions of current legislation.



Accessories available on request:

- Original supplied and optional accessories may be ordered from any Authorised Support Centre.
- Use only original accessories supplied by the manufacturer.

5.1 Using the rack or tray

The racks and trays are equipped with a mechanical safety lock which prevents them from being taken out accidentally. To insert the rack or tray correctly, check that the lock is facing downwards (as shown in the figure at the side).

To remove the rack or tray, lift the front slightly.

The mechanical lock (or the extension piece where present) must always face the back of the oven.

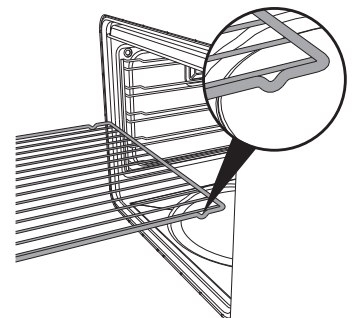

Gently insert racks and trays into the oven until they come to a stop.



In models with runners, clean the trays before using them for the first time. Cleaning will remove any manufacturing residues, which may otherwise scratch the sides of the oven cavity when trays are being inserted.



5.2 Using the support rack

The support rack is inserted into the tray (as shown in the figure). Using this, foods can be cooked and the fat can be collected separately from the food which is being cooked.



5.3 Using the reduction pan stands

The reduction pan stands should be placed on top of the hob pan stands as shown in the adjacent figure. Make sure they are stable.

The WOK pan stand should only be used when cooking with a wok.

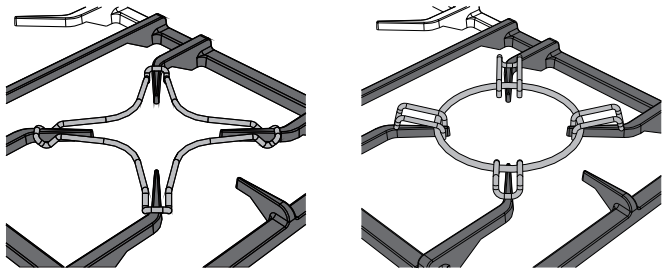

5.4 Using the rotisserie rod (on some models only)

When cooking with the rotisserie, position the frame on the third runner (see 7.2 Oven runners). Once the frame is inserted, the shaped part must sit facing outwards (as shown in the figure).

Then prepare the rotisserie rod with the food, using the clip forks provided.

So that you can handle the rod with the food on it readily, screw on the handle provided.

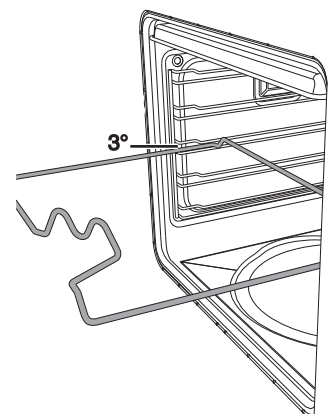

Having prepared the rotisserie rod with the food, position it on the guide frame as shown in the figure.

Insert the rod into the hole (detail B) so that it connects with the rotisserie motor.

Make sure that the pin is placed correctly on the guide frame (detail A).

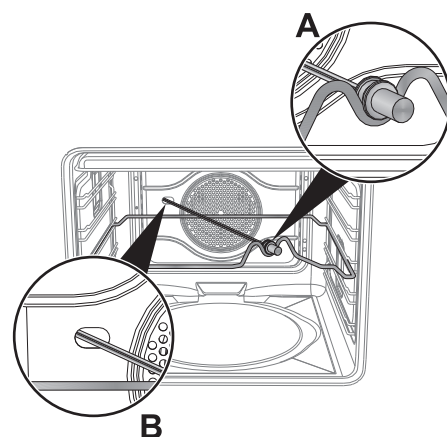



6. USING THE COOKING HOB

6.1 General warnings and advice



Before lighting the hob burners, make sure that the flame-spreader crowns are correctly positioned in their housings with their respective burner caps.



Before lighting the burners **lift the glass lid** (where present); before closing it again, turn off all the burners and wait for them to cool.

6.2 Lighting the hob burners

All the appliance's control and monitoring devices are placed together on the front panel. The burner controlled by each knob is shown next to the knob. The appliance is equipped with an electronic lighter. Simply press the knob and turn it anti-clockwise to the maximum flame symbol until the burner lights. If the burner does not light in the first 15 seconds, turn the knob to "0" and wait 60 seconds before trying again. After lighting, keep the knob pressed down for a few seconds to allow the thermocouple to heat up. The burner may go out when the knob is released: in this case, the thermocouple has not heated up sufficiently.

Wait a few moments and repeat the operation keeping the knob pressed for longer.

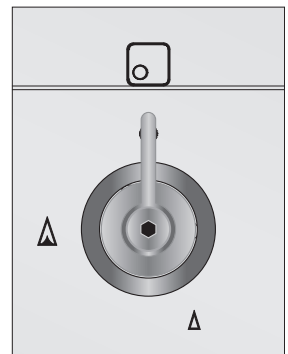

If the burners should go out accidentally, a safety device will be tripped, cutting off the gas supply, even if the gas tap is open. In this case, turn the knob to the OFF position and wait at least 60 seconds before trying to light the burner again.

6.3 Practical hints for using the hob burners

For better burner efficiency and to minimise gas consumption: use pans with lids and of a suitable size for the burner, so that the flames do not reach up the sides of the pan (see paragraph "6.4 Pan diameters"). Once the contents come to the boil, turn down the flame far enough to ensure that the liquid does not boil over. If any liquid does boil over or spill, remove the excess from the hob.

To prevent burns or damage to the hob during cooking, all pans or griddles must be placed inside the perimeter of the hob. All pans must have smooth, flat bottoms.

If the flame accidentally goes out, turn off the control knob and wait at least 1 minute before trying to re-light the burner.

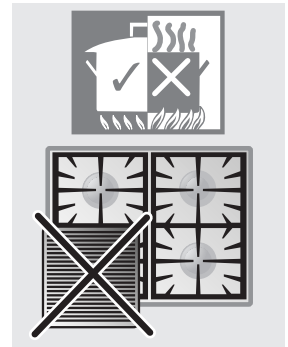

Take the greatest care when using fats or oils since they may catch fire if overheated.



6.4 Pan diameters

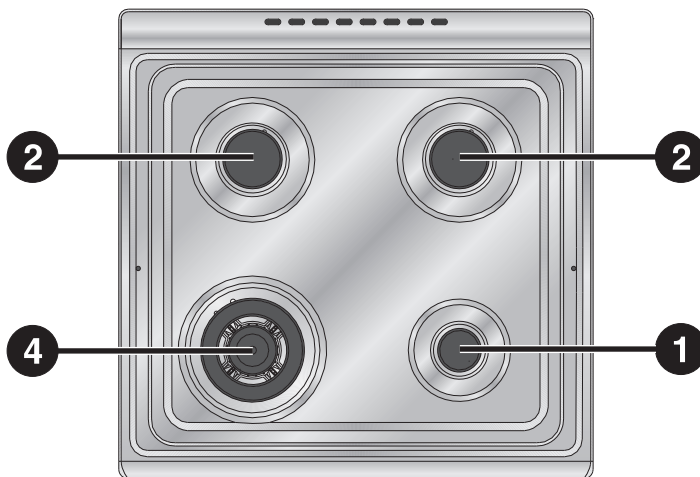

	Burner	Ø min. (cm)	Ø max. (cm)
1	Auxiliary	12	14
2	Semi-rapid	16	24
4	Ultra-rapid	18	26



To prevent damage to the appliance or adjacent units, all pans or griddles must be placed inside the perimeter of the hob.



Make sure never to come into contact with the lid glass with pots or pans that are still hot. The glass could crack and break with the heat.

6.5 Glass lid (on some models only)

The toughened glass lid with aluminium edging protects the hob when not in use.

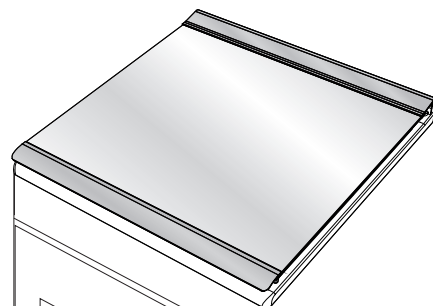

Make sure never to come into contact with the lid glass with pots or pans that are still hot. The glass could crack and break with the heat.



The lid must be raised (open) when the oven or hob is being used. Before lighting the burners **lift the glass lid**; before closing it again, turn off all the burners and wait for them to cool.



7. USING THE OVEN

7.1 Before using the appliance



- Remove any labels (apart from the technical data plate) from trays, dripping pans and the cooking compartment.
- Remove any protective film from the outside or inside of the appliance, including from accessories such as trays, dripping pans, the pizza plate or the base cover.
- Before using the appliance for the first time, remove all accessories from the oven compartment and wash them as indicated in "9. CLEANING AND MAINTENANCE".



Heat the empty appliance to the maximum temperature in order to remove any manufacturing residues which could affect the food with unpleasant odours.

7.2 Oven runners

The oven features 5 runners for positioning trays and racks at different heights. The insertion heights are indicated from the bottom upwards (see figure).

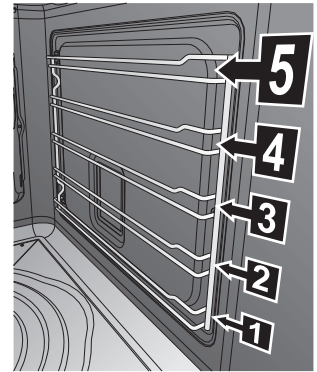

7.3 Storage compartment (on some models only)

The storage compartment is in the bottom of the cooker. It provides storage space for the appliance's metal accessories and must not be used to store flammable materials, cloths, paper etc..

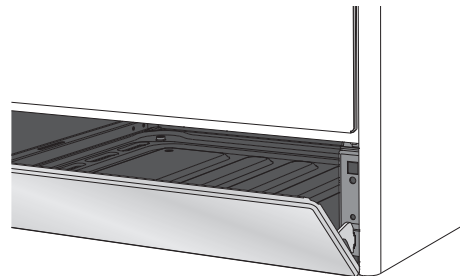

Do not open the storage compartment when the oven is on and still hot. The temperatures inside it may be very high.

7.4 Cooling fan system (on some models only)

The appliance is equipped with a cooling system which comes into operation as soon as a cooking function starts. The fan causes a steady outflow of air that exits from the rear of the appliance and which may continue for a brief period of time even after the appliance has been turned off.

7.5 Internal light

The oven light comes on when the door is opened (on some models only) or any function is selected.



7.6 General warnings and advice for use

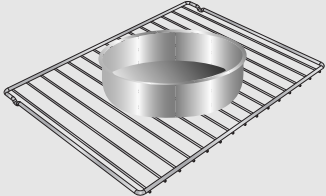
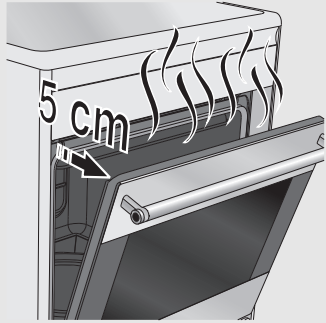



	<p>All cooking operations must be carried out with the door closed. The dissipation of heat may cause hazards.</p>
	<p>During cooking, do not cover the bottom of the oven with aluminium or tin foil and do not place pans or oven trays on it as this may damage the enamel coating. If you wish to use greaseproof paper, place it so that it will not interfere with the hot air circulation inside the oven.</p>
	<p>For the best cooking results, we recommend placing cookware in the centre of the rack.</p> 
	<p>To prevent any steam in the oven from causing problems, open the door in two stages: keep it half open (5 cm approx.) for 4-5 seconds and then fully open. To access food, always leave the door open as short a time as possible to prevent the temperature in the oven from falling and ruining the food.</p> 
	<p>To prevent excessive amounts of condensation from forming on the internal glass, hot food should not be left inside the oven for too long after cooking.</p>
	<p>While cooking desserts or vegetables, excessive condensation may form on the glass. In order to avoid this, open the door very carefully a couple of times while cooking.</p>
	<p>To prevent hazardous overheating, the appliance's lid (where present) must always be raised when using the oven.</p>
	<p>Heat the empty appliance to the maximum temperature in order to remove any manufacturing residues which could affect the food with unpleasant odours.</p>

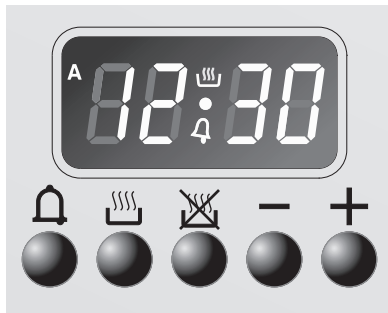





7.7 Electronic programmer



LIST OF FUNCTIONS

-  Timer key
-  End of cooking key
-  Cooking duration key
-  Value decrease key
-  Value increase key

7.7.1 Setting the time







On the first use, or after a power failure, **00:00** will be flashing on the oven's display. Press the  and  keys together, and at the same time press the  or  keys: this will increase or decrease the setting by one minute for each pressure.

Press either of the value modification keys to display the current time.

7.7.2 Using the timer





Warning: the timer does not stop the cooking operation. It only warns the user that the preset number of minutes have passed.

The programmer can also be used as an ordinary timer. Press ; the display will show the numbers **00:00**; press and hold  and use  or  to set the required number of minutes. When  is released, the countdown will start and  and  will appear on the display.



After the timer has been programmed, the display will go back to showing the current time; to display the remaining time, press .

7.7.3 Stopping the buzzer







The buzzer stops automatically after about seven minutes. It can be deactivated manually by pressing keys  and  together.

To switch off the oven, return the knobs to the **O** setting.

7.7.4 Semi-automatic cooking



Semi-automatic cooking is the function which allows a cooking operation to be started and then ended after a specific length of time set by the user.

Having selected a function, press and hold ; the display will show the numbers **00:00**; press and hold  and simultaneously use  or  to set the cooking time. When  is released, the programmed cooking time will start and the display will show the current time together with  and **A** (to indicate that a programmed cooking operation has been set).



7.7.5 Automatic cooking



Automatic cooking is the function which allows a cooking operation to be started at a set time and then ended after a specific length of time set by the user.

Having selected a function, press and hold ; the display will show the numbers ; press and hold and simultaneously use or to set the required number of minutes.

Press and the sum of the current time plus the preset cooking time will appear on the display. Press and hold and simultaneously press or to set the cooking end time.

When is released, the automatic cooking operation will start and the display will show the current time together with and **A** (to indicate that a programmed cooking operation has been set).



After making the setting, press the key to view the remaining cooking time; press the key to view the cooking end time.

7.7.6 End of semi-automatic / automatic cooking

At the end of the cooking time the oven will switch off automatically and simultaneously a buzzer will start to sound intermittently. After the buzzer has been deactivated, the display will return to show the current time together with the symbol to indicate that the oven has returned to manual use mode.

7.7.7 Deleting the set data

After having programmed semi-automatic or automatic cooking, the settings can be deleted by pressing keys and simultaneously. To switch off the oven, return the knobs to **O** setting. The programmer will interpret the cancellation of the program as terminating the cooking operation.

7.7.8 Modifying the set data

The set cooking data can be modified at any time by holding down the function key and at the same time pressing the keys or to change the value.

7.7.9 Adjusting the buzzer volume

The buzzer volume can be set to 3 different levels. When the buzzer is in operation, press to change the setting.



8. COOKING WITH THE OVEN

ECO

The ECO symbol indicates which function gives the least energy consumption.

BOTTOM:



The heat coming just from the bottom allows to complete the cooking of foods that require a longer basic cooking time, without affecting their browning. Perfect for cakes, pies, tarts and pizzas. This symbol also includes the cleaning function, see "9.6 VAPOR CLEAN: assisted oven cleaning (on some models only)".

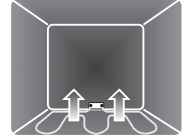

STATIC:



As the heat comes from above and below at the same time, this system is particularly suitable for certain types of food. Traditional cooking, also known as static or thermal radiation cooking, is suitable for cooking just one dish at a time. Perfect for all types of roasts, bread and cakes and in any case particularly suitable for fatty meats such as goose and duck.

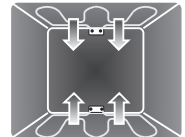

GRILL:



The heat coming from the grill element gives perfect grilling results above all for thin and medium thickness meat and in combination with the rotisserie (where present) gives the food an even browning at the end of the cooking. Perfect for sausages, ribs and bacon. This function enables large quantities of food, particularly meat, to be grilled evenly.

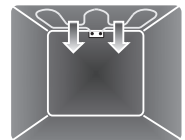

FAN-ASSISTED GRILL:



The air produced by the fan softens the strong heatwave generated by the grill, giving perfect grilling even to very thick foods. Perfect for large cuts of meat (e.g. shin of pork). We recommend using the 4th runner.



FAN-ASSISTED BOTTOM:



The combination of the fan with just the lower heating element allows cooking to be completed more rapidly. This system is recommended for sterilising or for finishing off the cooking of foods which are already well-cooked on the surface, but not inside, which therefore need a little more heat. Perfect for any type of food.



CIRCULAR:



The combination of the fan and the circular element (incorporated in the rear of the oven) allows to cook different foods on several levels, as long as they need the same temperatures and cooking time. Hot air circulation ensures instant and uniform distribution of heat. It will be possible, for instance, to cook fish, vegetables and biscuits simultaneously (on different levels) without mixing smells and flavours.

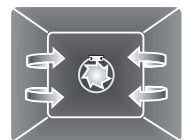



8.1 Cooking advice and instructions

8.1.1 General advice

- **We recommend preheating the oven before putting the food in.** Place the food in the oven only once the cooking light is off.
- For cooking on several levels, we recommend using a fan-assisted function to achieve uniform cooking at all heights.
- In general, it is not possible to shorten the cooking times by increasing the temperature (the food could be well-cooked on the outside and undercooked on the inside).
- While cooking desserts or vegetables, excessive condensation may form on the glass. In order to avoid this, open the door very carefully a couple of times while cooking.
- For rapid preheating use a fan-assisted function, then select the required function.

8.1.2 Advice for cooking meat

- Cooking times, especially for meat, vary according to the thickness and quality of the food and to consumer taste.
- We recommend using a meat thermometer for meat when roasting it. Alternatively, simply press on the roast with a spoon: if it is hard it is ready, if not, it needs another few minutes cooking.



8.1.3 Advice for cooking desserts and biscuits

- Use dark metal moulds for desserts: they help to absorb the heat better.
- The temperature and the cooking time depend on the quality and consistency of the dough.
- Check whether the dessert is cooked right through: at the end of the cooking time, put a toothpick into the highest point of the dessert. If the dough does not stick to the toothpick, the dessert is cooked.
- If the dessert collapses when it comes out of the oven, on the next occasion reduce the set temperature by about 10°C, selecting a longer cooking time if necessary.

8.1.4 Advice for defrosting and proving

- We recommend positioning frozen foods in a lidless container on the first runner of the oven.
- The food must be defrosted without its wrapping.
- Lay out the foodstuffs to be defrosted evenly, not overlapping.
- When defrosting meat, we recommend using a rack positioned on the second runner with the food on it and a tray positioned on the first runner. In this way, the liquid from the defrosting food drains away from the food.
- The most delicate parts can be covered with aluminium foil.
- For successful proving, a container of water should be placed in the bottom of the oven.

8.1.5 Advice for cooking with the Grill and the Fan-assisted grill

- Using the Grill function  (where present), meat can be grilled even when it is put into the oven cold; preheating is recommended if you wish to change the effect of the cooking.
- With the Fan-assisted grill function , however, we recommend that you preheat the oven before grilling.



8.2 Cooking process information table

Types of food	Weight	Function	Runner position from the bottom	Temperature °C	Time (minutes)	
FIRST COURSES						
Lasagne	3 kg	Static	1 or 2	220 - 230	40 - 50	
Oven-baked pasta		Static	1 or 2	220 - 230	40	
MEAT						
Roast veal	1 Kg	Fan-assisted static	2	180 - 190	70 - 80	
Pork loin	1 Kg	Static	2	190 - 200	70 - 80	
Shoulder of pork	1 Kg	Fan-assisted static	2	180 - 190	90 - 100	
Roast rabbit	1 Kg	Static	2	190 - 200	70 - 80	
Turkey breast	1 Kg	Fan-assisted static	2	180 - 190	110 - 120	
Roast neck of pork	1 Kg	Static	2	190 - 200	190 - 210	
Roast chicken	1 Kg	Fan-assisted static	2	180 - 190	60 - 70	
GRILLED MEATS						
Pork chops		Fan-assisted grill	4	250	1 st side	2 nd side
Fillet of pork		Fan-assisted grill	3	250	9 - 11	5 - 9
Fillet of beef		Fan-assisted grill	3	250	9 - 11	9 - 11
Liver		Fan-assisted grill	4	250	2 - 3	2 - 3
Sausages		Fan-assisted grill	3	250	7 - 9	5 - 6
Meatballs		Fan-assisted grill	3	250	7 - 9	5 - 6
ROTISSERIE MEAT (where present)						
Chicken		Rotisserie grill	On a	250	60 - 70	
FISH						
Salmon trout	0.7 Kg	Circular	2	160 - 170	35 - 40	
BREAD and FOCACCIA						
Pizza		Fan-assisted static	1	250	6 - 10	
Bread		Fan-assisted static	1	190 - 200	25 - 30	
Focaccia		Fan-assisted static	1	180 - 190	15 - 20	
DESSERTS						
Ring cake		Static	2	170	55 - 60	
Fruit tart		Fan-assisted static	2	160	30 - 35	
Fruit tart		Static	2	170	35 - 40	
Short pastry		Fan-assisted static	1 or 2	160 - 170	20 - 25	
Jam tarts		Static	2	170	20	
Paradise cake		Static	1 or 2	170	50 - 60	
Paradise cake		Fan-assisted static	2	160	50 - 60	
Light sponge cake		Static	2	150 - 160	50 - 60	
Rice pudding		Fan-assisted static	2	160	50 - 60	
Rice pudding		Static	2	170	50 - 60	
Croissants		Fan-assisted static	2	160	25 - 30	



The times indicated in the following tables do not include the preheating times and are provided as a guide only.



9. CLEANING AND MAINTENANCE



Do not use steam jets for cleaning the appliance. The steam could reach the electronics, damaging them and causing short-circuits.



WARNING: For your safety, you are advised to wear protective gloves while performing any cleaning or extraordinary maintenance.



Do not use cleaning products containing chlorine, ammonia or bleach on steel parts or parts with metallic finishes on the surface (e.g. anodizing, nickel- or chromium-plating).



We recommend the use of cleaning products distributed by the manufacturer.

9.1 Cleaning stainless steel

To keep stainless steel in good condition it should be cleaned regularly after use. Let it cool first.

9.2 Ordinary daily cleaning

To clean and preserve the stainless steel surfaces, always use only specific products that do not contain abrasives or chlorine-based acids.

How to use: pour the product onto a damp cloth and wipe the surface, rinse thoroughly and dry with a soft cloth or a microfibre cloth.

9.3 Food stains or residues



Do not use metallic sponges or sharp scrapers as they will damage the surfaces.

Use ordinary non-abrasive products with the aid of wooden or plastic utensils if necessary. Rinse thoroughly and dry with a soft cloth or a microfibre cloth.

Do not allow residues of sugary foods (such as jam) to set inside the oven. If allowed to set for too long, they could ruin the enamel covering the inside of the oven.

9.4 Cleaning the cooking hob parts

9.4.1 Glass lid (where present)



If liquids fall on the lid when it is closed, carefully remove them with a cloth before opening it.

For easier cleaning, the lid can be taken off its hinges.

- 1 Lower the lid to closed position.
- 2 Unscrew the screws positioned on the back of the two hinges (indicated for the various models by the arrow in the figure) and lift it upwards.
- 3 Clean.
- 4 Insert the lid into the guides. Tighten the fastening screws on the hinges in closed position.

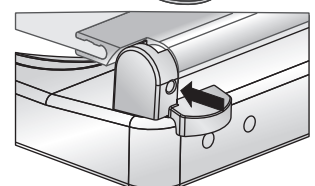
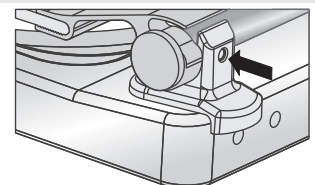

Annual service by an authorised person is recommended, or if any of the following conditions are noticed; incomplete ignition, appreciable yellow tipping, carbon deposition, lifting, floating, lighting back or objectionable odour.



9.4.2 Pan stands

Remove the pan stands and clean them with lukewarm water and non-abrasive detergent, making sure to remove any encrustations. Dry them thoroughly and return them to the hob.

Continuous contact between the pan stands and the flame can cause modifications to the enamel over time in those parts exposed to heat. This is a completely natural phenomenon which has no effect on the operation of this component.

9.4.3 Burner caps and flame-spreader crowns

The burner caps and flame-spreader crowns can be removed for easier cleaning. Wash them in warm water and a non-abrasive detergent making sure to remove any encrustation, then wait until they are perfectly dry.

Refit the flame-spreader crowns, making sure that they are correctly in place with their respective burner caps, and ensuring that the holes **A** in the flame-spreaders are aligned with the igniters and thermocouples.

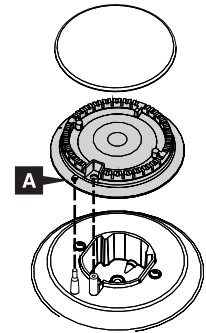

Do not wash these parts in a dishwasher.

9.4.4 Igniters and thermocouples

For correct operation, the igniters and thermocouples must always be perfectly clean. Check them frequently and clean them with a damp cloth if necessary. Remove any dry residues with a wooden toothpick or a needle.

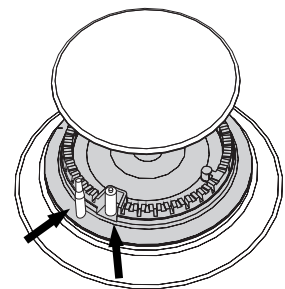

Do not use cleaning products containing chlorine, ammonia or bleach on steel parts or parts with metallic finishes on the surface (e.g. anodizing, nickel- or chromium-plating).



9.5 Cleaning the oven

For the best oven upkeep, clean it regularly after having allowed it to cool.

- Take out all removable parts.
- Clean the oven racks with hot water and non-abrasive detergent. Rinse and dry.
- For easier cleaning, the door can be removed (see “10.2 Removing the door”).

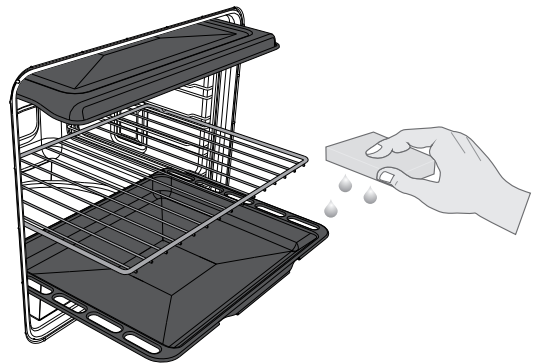

The oven should be operated at the maximum heat setting for 15/20 minutes after use of specific products, to burn off the residues left inside the oven.



When the operation is complete, damp parts should be dried thoroughly.

9.5.1 Removing guide frames

Removing the guide frames enables the sides to be cleaned more easily. This should be done each time the automatic cleaning cycle is used (on some models only).

To remove the guide frames:

- 1 pull the frame towards the inside of the oven to unhook it from its housing A, then slide it out of the seats at the back B.
- 2 When cleaning is complete, repeat the above procedures to put the guide frames back in.

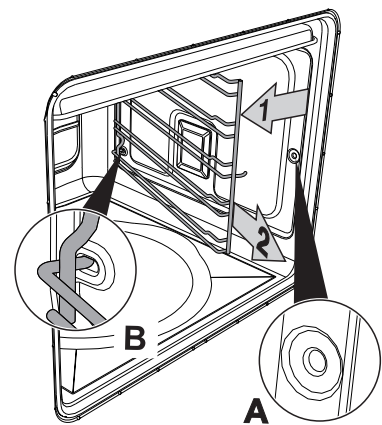

9.5.2 Cleaning the door glazing

The glass in the door should always be kept thoroughly clean. Use absorbent kitchen roll; remove stubborn dirt with a damp sponge and an ordinary detergent.



Do not use abrasive or corrosive detergents to clean the oven's glass doors (e.g. powder products, spot-removers and wire sponges). Do not use rough or abrasive materials or sharp metal scrapers to clean the oven's glass doors since they may scratch the surface.

9.5.3 Cleaning the door seal

To keep the seal clean, use a non-abrasive sponge and lukewarm water. The seal should be soft and flexible (with the exception of pyrolytic models).

In pyrolytic models, the seal may flatten over time and lose its original shape. To restore it, pinch the seal all the way along. This also helps remove any dirt on the seal.



9.6 VAPOR CLEAN: assisted oven cleaning (on some models only)



VAPOR CLEAN is an assisted cleaning procedure which facilitates the removal of dirt. Thanks to this process, it is possible to clean the inside of the oven with great ease. The dirt residues are softened by the heat and water vapour for easier removal afterwards.



Before starting the assisted cleaning cycle, make sure that the oven does not contain any foods or large spills from previous cooking operations.



Carry out assisted oven cleaning operations only when the oven is cold.

9.6.1 Before starting the assisted cleaning cycle



Completely remove all accessories from inside the oven. The roof lining can be left inside the oven (where present).

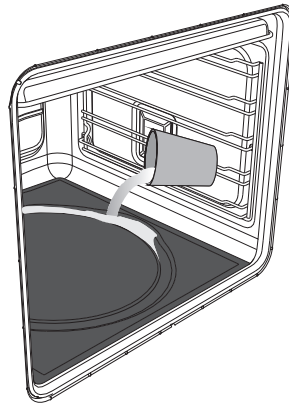

Pour approx. 40 cc of water onto the floor of the oven (as shown in the figure). Make sure it does not overflow out of the cavity.

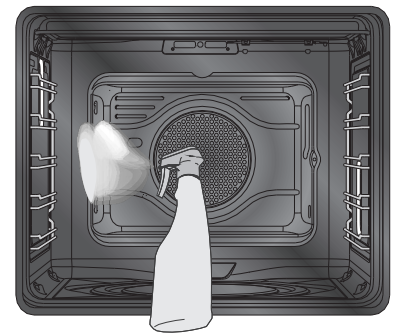

Spray a water and washing up liquid solution inside the oven using a spray nozzle. Aim the spray towards the oven cavity. At the end of this process, close the door and set the cleaning cycle.





Do not spray excessive amounts of the water and washing up liquid solution. We recommend spraying approx. 20 times at the most.



9.6.2 Setting the assisted cleaning cycle

Once the preparations have been made for the assisted cleaning cycle, proceed as follows:

- 1 Turn the function knob to the symbol  and the temperature selection knob to the symbol  for the VAPOR CLEAN function.
- 2 Set a cooking time of 15 minutes using the electronic programmer.
- 3 At the end of the assisted cleaning cycle, the timer will deactivate the oven heating elements.

9.6.3 End of the assisted cleaning cycle



The water remaining at the end of the assisted cleaning cycle cannot be left inside the oven for long (for example overnight).



You are advised to wear a pair of gloves during these processes.

At the end of the cleaning cycle, open the door and wipe away the less stubborn dirt with a microfibre cloth. Use an anti-scratch sponge with brass filaments on tougher encrustations.

We recommend removing the door as described in “10.2 Removing the door” to facilitate access to restricted spaces.

For improved hygiene and to avoid food being affected by any unpleasant odours, we recommend that the oven is dried using a fan function at 160°C for approximately 10 minutes. To set the function, see “4.1.2 Function selection knob”.



If the VAPOR CLEAN cycle is activated after fatty cooking operations, of meat in particular, it may be necessary to use an oven cleaning product at the end of the cycle to completely remove any stubborn residue.



10. EXTRAORDINARY MAINTENANCE

The oven requires periodic minor maintenance or replacement of parts subject to wear, such as gaskets, light bulbs, etc. Specific instructions for each operation of this kind are given below.



Before any intervention that requires access to live parts, disconnect the appliance from the power supply.



WARNING: For your safety, you are advised to wear protective gloves while performing any cleaning or extraordinary maintenance.

10.1 Replacing the light bulb

If a light bulb needs to be replaced because it is worn or burnt out, remove the guide frames; see "9.5.1 Removing guide frames".

Then remove the bulb cover using a tool (e.g. a screwdriver).

Remove the bulb by unscrewing (filament bulbs) or pulling it (halogen bulbs) in the indicated direction. Replace the bulb with one of the same type (25W for filament bulbs or 40W for halogen bulbs).

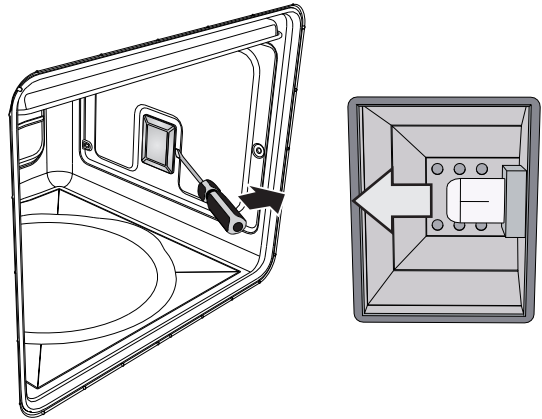

Do not touch halogen bulbs directly with your fingers, wrap them in insulating material.

10.2 Removing the door

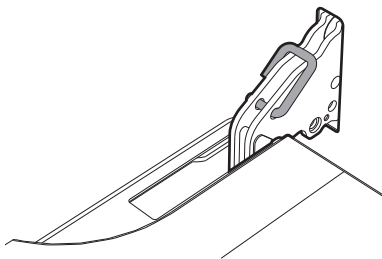

Open the door completely. Insert a pintle into the hole in the hinge. Repeat for both hinges.

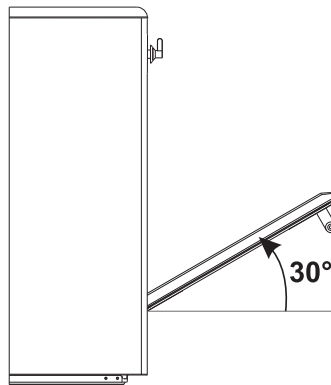

Grasp the door on both sides with both hands, lift it forming an angle of around 30° and remove it.

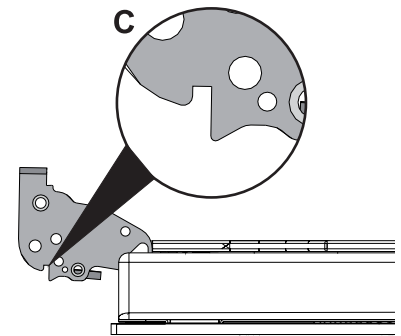

To reassemble the door, put the hinges in the relevant slots in the oven, making sure that grooved sections C are resting completely at the base of the slots. Lower the door and once it is in place remove the pins from the holes in the hinges.



10.3 Removing the door seal (not on pyrolytic models)

To permit thorough cleaning of the oven, the door seal may be removed.

There are fasteners on all four sides to attach it to the edge of the oven. Pull the edges of the seal outwards to detach the fasteners. The seal must be replaced when it loses elasticity and hardens.

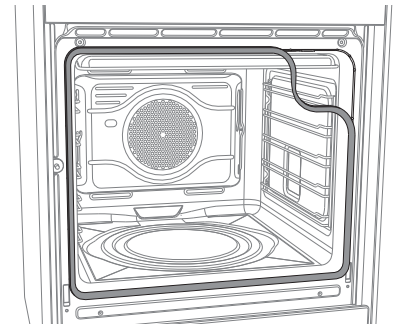

10.4 Removing the internal glass panels

The glass in the door should always be kept thoroughly clean. To facilitate cleaning, it is possible to remove the door (see 10.2 Removing the door) and place it on a canvas, or open it and lock the hinges in order to extract the glass panels. The glass panels of the door can be completely removed by following the instructions provided below.



Warning: before removing the glass panels, make sure that at least one of the door's hinges has been locked in the open position as described in chapter "10.2 Removing the door". This operation may have to be repeated during the glass removal process if the door is accidentally freed.

Removing the internal glass panel:

- Remove the internal glass panel by pulling the rear part gently upwards, following the movement indicated by the arrows (1).
- Then pull the front of the glass panel upwards (2).
- Doing this detaches the 4 pins attached to the glass from their slots in the oven door.

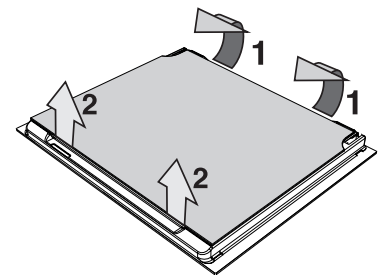

Removing the middle glass panels:

- (pyrolytic models) there are two middle glass panels attached using 4 small locks. Remove the middle panels by lifting them upwards.
- (other models) an intermediate glass panel may be present; if so, remove it by lifting it upwards.

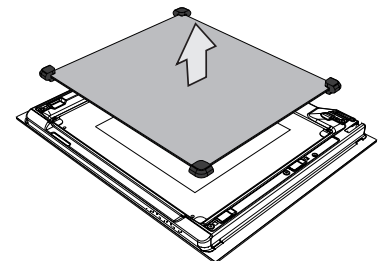

Cleaning:

- It is now possible to clean the external glass panel and the panels removed previously. Use absorbent kitchen roll. In the case of stubborn dirt, wash with a damp sponge and neutral detergent.

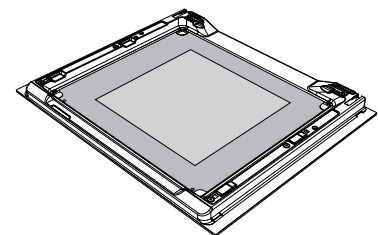

Replacing the glass panels:

- Replace the panels in the opposite order to which they were removed.
- Reposition the internal glass panel, taking care to centre and insert the 4 pins attached to the glass into their slots in the oven door by applying slight pressure.

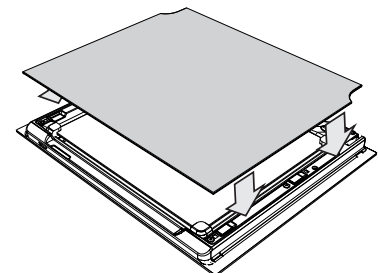



11. INSTALLATION

11.1 Minimum clearance to combustible surfaces

Freestanding cooker

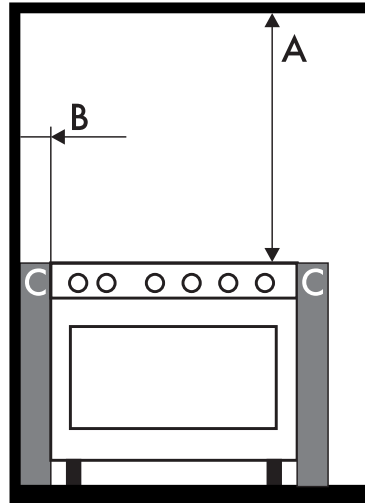

A 600 mm (Overhead) measured from the highest part of the highest burner and 750 mm for an exhaust fan

B 200 mm (Vertical combustible surface) measured from the edge of the nearest burner.

C 10 mm (Horizontal combustible surface) below the hob.



Refer to AS/NZS 5601 (Protection of a combustible surface) if the above minimum clearances cannot be achieved.



The appliance connection point shall be accessible with the appliance installed.



11.2 Combustion gas discharge



Combustion gases may be discharged by means of hoods connected to a flue with reliable natural draught, or a fan extraction system. An effective extraction system requires careful design by an authorised specialist, and must comply with the regulation distances and positions. After installation, the engineer must issue a certificate of compliance.

11.3 Gas connection

This appliance must be installed by an authorised person in accordance with this instruction manual, AS/NZS 5601 - Gas installations (installation and pipe sizing), local gas fitting regulations, local electrical regulations, local water regulations, Building Code of Australia and any other government authority.

This appliance is suitable for connection with rigid pipe or flexible hose. The isolating manual shut-off valve connection point must be accessible when the appliance is installed.

Flexible hose assembly must be certified to AS/NZS 1869 class B or D, be of appropriate internal diameter for the total gas consumption, be kept as short as possible (not exceeding 1200mm), must not be in contact with the floor or any hot sharp surfaces. The hose assembly must not be subject to strain, abrasion, kinking or deformation.

In case the appliance fails to operate correctly after all checks have been carried out, refer to the authorised service provider in your area. Gas leakage and operation of the appliance must be tested by the installer before leaving. Check burner flames are blue in colour, stable and completely ignite at both high and low flame settings with no appreciable yellow tipping, carbon deposition, lifting, floating, lighting back or objectionable odour. Test burners individually and in combination. When satisfied with the operation of the cooker, please instruct the user on the correct method of operation.

Natural Gas: the regulator must be fitted to the appliance inlet connection. Gas pressure must be adjusted to 1.0 kPa when approximately 50% of the burners are on high flame, the appliance test point is located on the regulator.

Universal LPG.: (the appliance test point is located at the injector)

Gas pressure must be checked to confirm the appliance operating pressure is 2.75 kPa, the appliance test point is the Rapid burner injector as shown on the right.

1. Disconnect power.
2. Light Auxiliary burner and set to high flame. Ensure all other burners are off.
3. Zero manometer, then apply flexible tubing to seal over the Rapid burner injector, hold securely in place and check the gas pressure by pressing in the corresponding burner control knob, then turning to high flame position.
4. If the pressure is 2.75 kPa, reassemble the burner and perform the final checks as per this instruction manual.
5. If the pressure is **not** 2.75 kPa, disconnect the appliance and check/adjust/replace the LPG cylinder regulator(s) as appropriate in accordance with AS/NZS 5601.

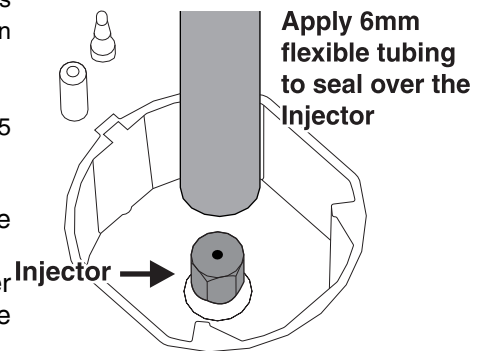

Alternative: test point adaptor can be fitted to the appliance inlet connection. Gas pressure must be checked at 2.75 kPa.



Installation with flexible hose must be carried out so that the length of the piping does not exceed 2 metres when fully extended; make sure that the hoses do not come into contact with moving parts and that they are not crushed in any way.

11.4 Room ventilation



The room containing the appliance should have a permanent air supply in accordance with the standards in force. The room where the appliance is installed must have enough air flow needed for the regular combustion of gas and the necessary air change in the room itself. The hob shall be installed in rooms with natural ventilation, as required by Standards regulations AS/NZS5601.



11.5 Extraction of the combustion products



The combustion products may be extracted by means of hoods connected to a natural draught chimney whose efficiency is certain or via forced extraction. An efficient extraction system requires precision planning by a specialist qualified in this area and must comply with the positions and distances indicated by the regulations. When the job is complete, the installer must issue a certificate of conformity.

11.6 Electrical connection



Make sure the voltage and the cross-section of the power supply line match the specifications indicated on the identification plate positioned on the appliance. Do not remove this plate for any reason. A copy of the plate is attached to the instructions.



The appliance must be connected to the power supply by a qualified technician.



Before performing any operations, switch off the power supply to the appliance.



The appliance must be connected to earth in compliance with electrical system safety regulations.



Where the appliance is connected to the power grid via a plug and socket, both of these must be of the same type and connected to the power cable in accordance with the regulations in force. The socket must be accessible after the appliance has been built in.

NEVER UNPLUG BY PULLING ON THE CABLE.



Should the earthing wire need replacing it must be longer than the current conduction wires so that, if the plug is torn off the power cable, it is the last to be detached.



Avoid use of adapters and shunts as these could cause overheating and risk of burns.



If a fixed connection is being used, fit the power line with an omnipolar circuit breaker with a contact opening gap equal to or greater than **3 mm**, in an easily accessible position close to the appliance.



The manufacturer declines all responsibility for damage to persons or things caused by non-observance of the above prescriptions or by interference with any part of the appliance.

APPLIANCE TYPE (CM)	POSSIBLE CONNECTION TYPES	CABLE TYPE (if not present)
60	<p>220 - 240 V 1N~</p>	<p>3-pole 3 x 1.5 mm² H05V2V2-F</p> <p>20 mm appliance side</p>



Instructions for the installer

EN



- Use H05V2V2-F cables resistant to at least 90°C.
- The values indicated above refer to the cross-section of the internal conductor.
- The tightening torque of the screws of the terminal supply wires must be 1.5 - 2 Nm.
- The aforementioned power cables are sized taking into account the coincidence factor (in compliance with standard EN 60335-2-6).



11.7 Positioning the skirt (on some models only)

The skirt must always be positioned and secured correctly on the appliance.

- 1 Unscrew the 2 nuts (**B**) on the back of the worktop.
- 2 Position the skirt above the worktop, taking care to align the pins (**C**) with the holes (**D**).
- 3 Secure the skirt to the worktop by tightening screws (**A**).

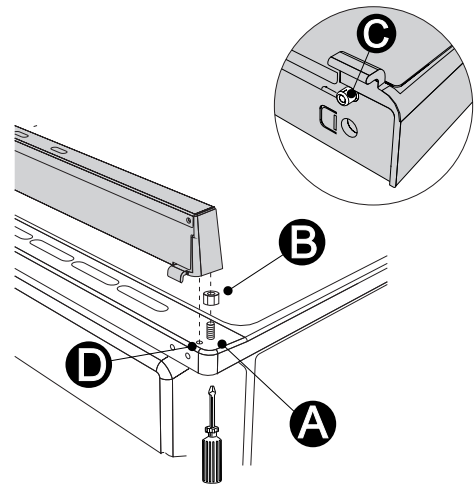

11.8 Positioning and levelling the appliance

After making the electrical and/or gas connections, level the appliance on the floor by means of its four adjustable feet. First insert the front feet and then the rear feet. The appliance must be properly levelled to ensure better stability. Screw or unscrew the bottom part of the foot until the appliance is stable and level on the floor.

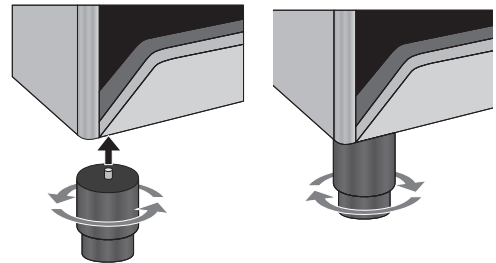

To prevent possible damage to the appliance, we recommend to screw first the front feet and then the rear ones.

11.9 Wall mounting brackets (where present)

The fastening system provided must be installed to ensure the appliance is stable. If installed correctly, this system prevents the appliance tipping over.

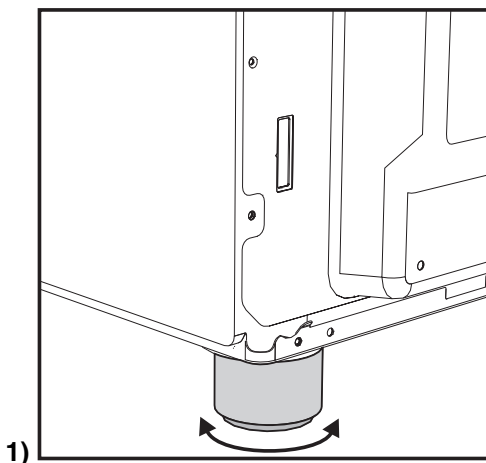

1) Use the adjustable feet to level the appliance at the required height.

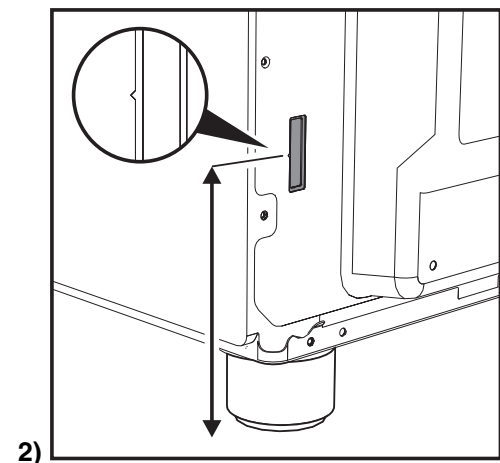

2) Measure the distance from the index of the opening to the floor.

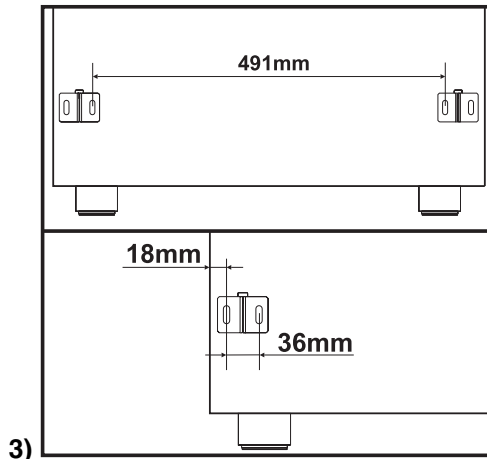

3) Use the same height on the wall to drill the holes for fastening the brackets. The distance between the centres of the holes is given in the diagram above.

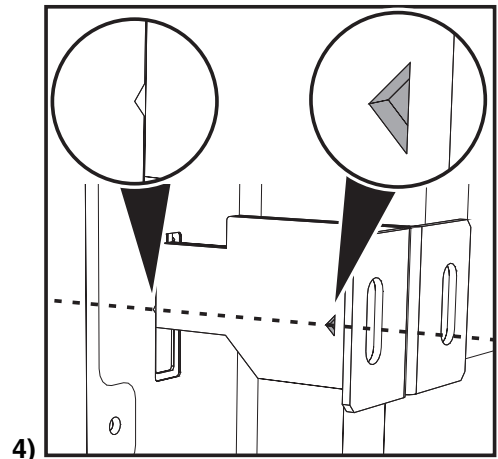

4) Before tightening the brackets fully to the wall, check that the index on the brackets is at the same height as the index on the back of the appliance. Position the appliance, taking care that the brackets are correctly inserted.

11.10 Wall fixing

- 1 Attach the chain to the cooker
- 2 Stretch out the chain attached to the cooker horizontally so that the other end touches the wall.
- 3 Mark the wall in the position where the hole is to be drilled.
- 4 Drill the hole, insert a wall plug and attach the chain.
- 5 Once the chain is in position, push the cooker against the wall and reduce the amount of chain links to keep the chain tight to prevent any excess movement.

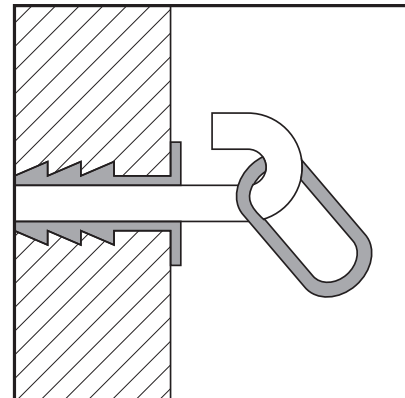
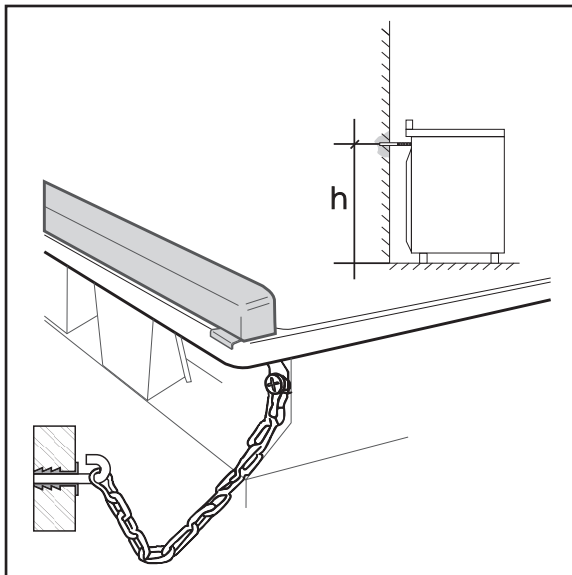



12. ADAPTATION TO DIFFERENT TYPES OF GAS



BEFORE PERFORMING ANY OPERATIONS, SWITCH OFF THE POWER SUPPLY TO THE APPLIANCE.

Appliance set for gas: **Natural gas at a pressure of 1.0 kPa** (see label on product)

In the case of operation with other types of gas, the burner nozzles must be changed and the minimum flame adjusted on the gas taps.

To change the nozzles, proceed as described in the following paragraphs.

12.1 Replacement of nozzles on the hob

- 1 Remove the pan stands, and remove all the burner caps and flame-spreader crowns to access the burner casings.
- 2 Unscrew the nozzles using a 7 mm socket wrench.
- 3 Replace the burner nozzles according to the type of gas to be used (see 12.3 Burner and nozzle characteristics table).
- 4 Replace the burners in the correct position.

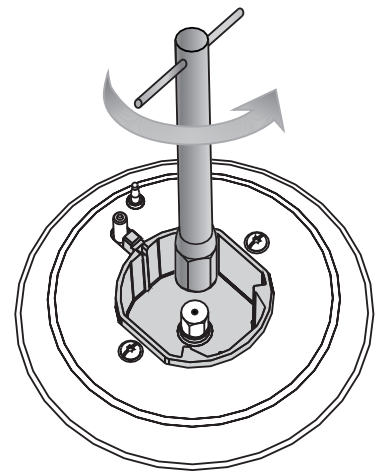

12.2 Arrangement of burners

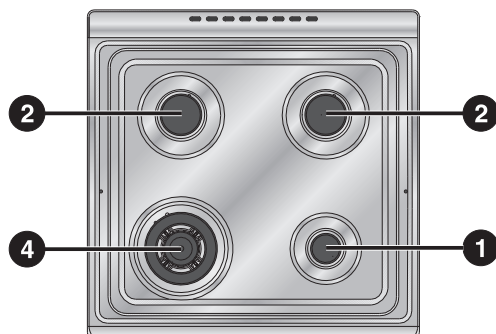

Burner	
1	Auxiliary
2	Semi-rapid
4	Ultra-rapid



12.3 Burner and nozzle characteristics table

Burner	ULPG - 2.75 kPa	
	Nominal gas consumption (MJ/h)	Injector (1/100 mm)
Auxiliary	3.9	54
Semi-rapid	6.3	68
Ultra-rapid	15.0	105

Burner	NG - 1.0 kPa	
	Nominal gas consumption (MJ/h)	Injector (1/100 mm)
Auxiliary	3.9	90
Semi-rapid	7.5	120
Ultra-rapid	15.0	175

12.4 Final operations

After replacing the nozzles, reposition the flame-spreader crowns, the burner caps and the pan stands.



Following adjustment to a gas other than the one originally set in the factory, replace the gas setting label fixed to the appliance with the one corresponding to the new gas. The label is inserted inside the nozzle pack (where present).

12.4.1 Adjusting the hob burner minimum for city or natural gas

Light the burner and turn it to the minimum position. Extract the gas tap knob and turn the adjustment screw next to the tap rod (depending on the model) until the correct minimum flame is achieved.

Refit the knob and verify that the burner flame is stable (when turning the knob rapidly from the maximum to the minimum position the flame must not go out). Repeat the operation on all the gas taps.

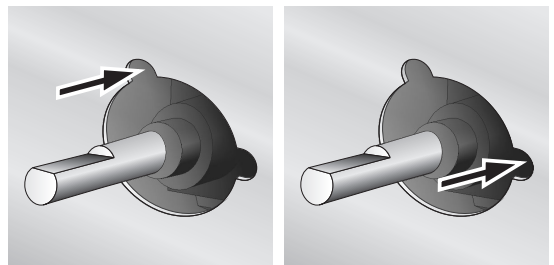

12.4.2 Adjusting the hob burner minimum for LPG gas

In order to adjust the minimum setting with liquid gas, the screw at the side of the tap rod must be tightened clockwise all the way.



914775525/H