

TABLE OF CONTENTS

COOKTOP SAFETY	2	Control Lock	7
COOKTOP USE	4	Performance Boost Function	7
Induction Cooking	5	Timer	8
Cooktop Controls	5	Tones	9
Dual Size Surface Cooking Area	6	Ceramic Glass	9
Simmer	7	Cookware	9
Melt + Hold	7	COOKTOP CARE	10
Bridge	7	General Cleaning	10
Pan Detection	7	TROUBLESHOOTING	10
		WARRANTY	10

TABLE DES MATIÈRES

SÉCURITÉ DE LA TABLE DE CUISSON	14	Verrouillage des commandes	20
UTILISATION DE LA TABLE DE CUISSON	17	Fonction d'optimisation du rendement	21
Cuisson par induction	18	Minuterie	22
Commandes de la table de cuisson	18	Signaux sonores	22
Surface de cuisson à dimension double	19	Vitrocéramique	22
Mijotage	19	Ustensiles de cuisson	23
Faire fondre et maintenir au chaud	20	ENTRETIEN DE LA TABLE DE CUISSON	23
Liaison	20	Nettoyage général	23
Détection d'un plat	20	DÉPANNAGE	24
		GARANTIE	26

Para obtener acceso al instrucciones en español, o para obtener información adicional acerca de su producto, visite:
www.smegusa.com

COOKTOP SAFETY

Your safety and the safety of others are very important.

We have provided many important safety messages in this manual and on your appliance. Always read and obey all safety messages.



This is the safety alert symbol.

This symbol alerts you to potential hazards that can kill or hurt you and others.

All safety messages will follow the safety alert symbol and either the word "DANGER" or "WARNING."

These words mean:

⚠ DANGER

You can be killed or seriously injured if you don't immediately follow instructions.

⚠ WARNING

You can be killed or seriously injured if you don't follow instructions.

All safety messages will tell you what the potential hazard is, tell you how to reduce the chance of injury, and tell you what can happen if the instructions are not followed.

State of California Proposition 65 Warnings:

WARNING: This product contains one or more chemicals known to the State of California to cause cancer.

WARNING: This product contains one or more chemicals known to the State of California to cause birth defects or other reproductive harm.

IMPORTANT SAFETY INSTRUCTIONS

WARNING: To reduce the risk of fire, electrical shock, injury to persons, or damage when using the cooktop, follow basic precautions, including the following:

- **CAUTION:** Do not store items of interest to children in cabinets above a cooktop – Children climbing on the cooktop to reach items could be seriously injured.
- Proper Installation – Be sure your cooktop is properly installed and grounded by a qualified technician.
- Never Use Your Cooktop for Warming or Heating the Room.
- Do Not Leave Children Alone – Children should not be left alone or unattended in area where cooktop is in use. They should never be allowed to sit or stand on any part of the cooktop.
- Wear Proper Apparel – Loose-fitting or hanging garments should never be worn while using the cooktop.
- User Servicing – Do not repair or replace any part of the cooktop unless specifically recommended in the manual. All other servicing should be referred to a qualified technician.
- Storage on Cooktop – Flammable materials should not be stored near surface units.
- Do Not Use Water on Grease Fires – Smother fire or flame or use dry chemical or foam-type extinguisher.
- Use Only Dry Potholders – Moist or damp potholders on hot surfaces may result in burns from steam. Do not let potholder touch hot heating elements. Do not use a towel or other bulky cloth.
- DO NOT TOUCH SURFACE UNITS OR AREAS NEAR UNITS – Surface units may be hot even though they are dark in color. Areas near surface units may become hot enough to cause burns. During and after use, do not touch, or let clothing or other flammable materials contact surface units or areas near units until they have had sufficient time to cool. Among those areas are the cooktop and surfaces facing the cooktop.
- Use Proper Pan Size – This cooktop is equipped with one or more surface units of different size. Select utensils having flat bottoms large enough to cover the surface unit heating element. The use of undersized utensils will expose a portion of the heating element to direct contact and may result in ignition of clothing. Proper relationship of utensil to burner will also improve efficiency.
- Never Leave Surface Units Unattended at High Heat Settings – Boilover causes smoking and greasy spillovers that may ignite.
- Glazed Cooking Utensils – Only certain types of glass, glass/ceramic, ceramic, earthenware, or other glazed utensils are suitable for cooktop service without breaking due to the sudden change in temperature.
- Utensil Handles Should Be Turned Inward and Not Extend Over Adjacent Surface Units – To reduce the risk of burns, ignition of flammable materials, and spillage due to unintentional contact with the utensil, the handle of a utensil should be positioned so that it is turned inward, and does not extend over adjacent surface units.
- Do Not Cook on Broken Cooktop – If cooktop should break, cleaning solutions and spillovers may penetrate the broken cooktop and create a risk of electric shock. Contact a qualified technician immediately.
- Clean Cooktop With Caution – If a wet sponge or cloth is used to wipe spills on a hot cooking area, be careful to avoid steam burn. Some cleaners can produce noxious fumes if applied to a hot surface.

For units with ventilating hood –

- Clean Ventilating Hoods Frequently – Grease should not be allowed to accumulate on hood or filter.
- When flaming foods under the hood, turn the fan on.

For units with coil elements –

- Make Sure Reflector Pans or Drip Bowls Are in Place – Absence of these pans or bowls during cooking may subject wiring or components underneath to damage.
- Protective Liners – Do not use aluminum foil to line surface unit drip bowls, except as suggested in the manual. Improper installation of these liners may result in a risk of electric shock, or fire.
- Do Not Soak Removable Heating Elements - Heating elements should never be immersed in water.

SAVE THESE INSTRUCTIONS

This induction cooktop generates and uses ISM frequency energy that heats cookware by using an electromagnetic field. It has been tested and complies with Part 18 of the FCC Rules for ISM equipment. This induction cooktop meets the FCC requirements to minimize interference with other devices in residential installation.

This induction cooktop may cause interference with television or radio reception. If interference occurs, the user should try to correct the interference by:

- Relocating the receiving antenna of the radio or television.
- Increasing the distance between the cooktop and the receiver.
- Connecting the receiver into a different outlet.

It is the user's responsibility to correct any interference.

NOTE: People with a pacemaker or similar medical device should use care when standing near this induction cooktop while it is on. The electromagnetic field may affect the pacemaker or similar device. Consult your doctor, or the manufacturer of the pacemaker or similar medical device for additional information about its effects with electromagnetic fields of the induction cooktop.

COOKTOP USE

This manual covers different models. The cooktop you have purchased may have some or all of the features listed.

30" (76.2 cm) SIMU530

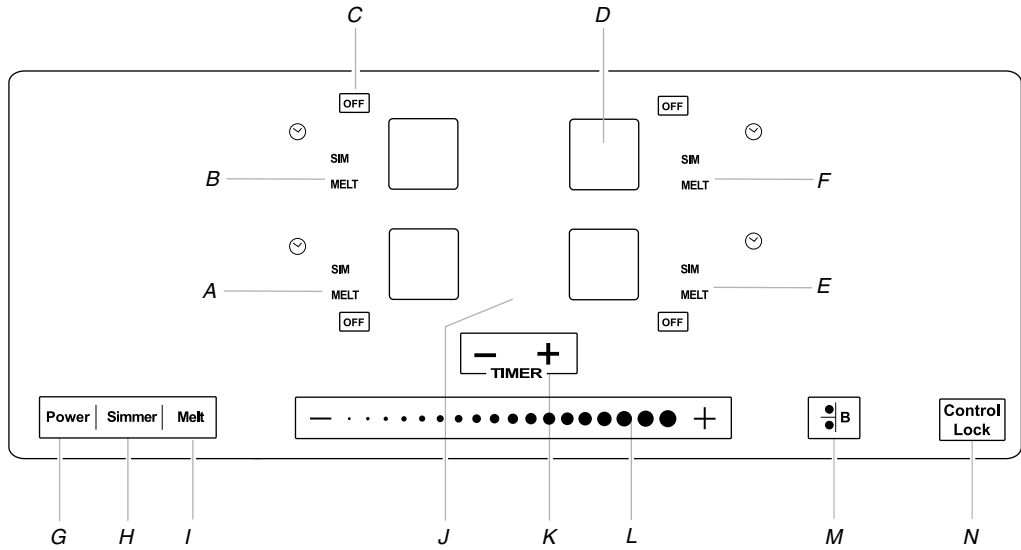

- A. Left front surface cooking area display
- B. Left rear surface cooking area display
- C. Surface cooking area off
- D. Heat level display

- E. Right rear surface cooking area display
- F. Right front surface cooking area display
- G. Power on/off
- H. Simmer
- I. Melt + Hold

- J. Timer display
- K. Timer (increase/decrease)
- L. Heat level slider
- M. Left side bridge
- N. Control lock

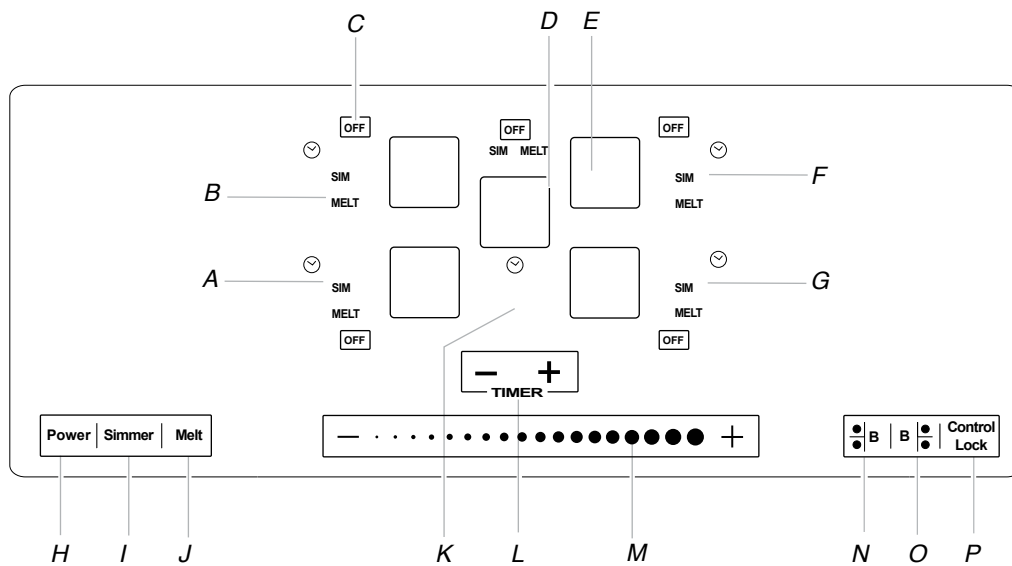

- A. Left front surface cooking area display
- B. Left rear surface cooking area display
- C. Surface cooking area off
- D. Center surface cooking area display
- E. Heat level display
- F. Right rear surface cooking area display
- G. Right front surface cooking area display
- H. Power on/off
- I. Simmer
- J. Melt + Hold
- K. Timer display
- L. Timer (increase/decrease)
- M. Heat level slider
- N. Left side bridge
- O. Right side bridge
- P. Control lock

Induction Cooking

Induction cooking is quite different from traditional forms of cooking. The heat is generated directly in the pan, keeping the cooking surface cooler than a traditional element.

Induction cooking does not lose as much heat as traditional forms because all the heat is created in the pan itself.

The cooktop heats up or cools down quickly after the controls are set. It also stops heating when the pan is removed without turning off the power.

Food spilled on the cooktop surface will not burn because the glass is not heated. Induction cooking allows for immediate cleaning after use because the heat is created in the pan.

Pan size, material (see "Cookware" section), and positioning is very important to achieve maximum wattage.

The diameter of the pan's base should be equal to the size of the element.

If the pan is too small, the burner does not sense the pan and will not activate.

Cooktop Controls

⚠ WARNING



Fire Hazard

**Turn off all controls when done cooking.
Failure to do so can result in death or fire.**

The touch-activated electronic controls offer a variety of heat settings for optimal cooking results. When melting foods such as chocolate or butter, the surface cooking area can be set to the Melt function for minimal cooking power.

For maximum surface cooking power, all cooktop touch-activated electronic controls can be set to Performance Boost function when bringing liquids to a fast and rapid boil. Touch BOOST to immediately reach the highest setting.

NOTE: This cooktop will also work with a 208V operation where 240V installation is not available.

First use or after a power failure:

After connecting the cooktop to an electrical power supply or after a power failure, the control panel will be locked. An indicator light above the key icon will be on. To unlock the control panel, press and hold CONTROL LOCK for 3 seconds. The indicator light will turn off, and the cooktop is ready for use.

To Use

To Turn On the Cooktop:

Press POWER.

1. The indicator light above the Power keypad and a dash (“-”) in each surface cooking area will light to indicate that each surface cooking area is ready to be activated.

Inactivity for 1 minute after the main power has been turned on will automatically turn off the power to the cooktop.

If a cooking function or the power slider is touched without first selecting a surface cooking area, all dashes (one for each zone) will flash and an invalid tone will sound 3 times.

To Turn On a Surface Cooking Area:

1. Touch directly on the display area for the surface cooking area you want to use.

The current power level and indicator light will flash for 10 seconds and then remain on.

Touching any other feature or the power slider stops the flashing and information for the keypad that was touched will be displayed.

When a surface cooking area is selected, the timer will also turn on to show that it can now be set.

When a surface cooking area is left at the “0” power level for 1 minute, the surface cooking area will automatically turn off and display only the middle dash without the indicator light.

2. Select a heat setting from 1 - 9 by touching/sliding on the power slider. The heat setting will appear in the surface cooking area display.

The power slider consists of 9 positions plus a “Boost” position. When the user slides to 0, “0” will be displayed. The surface cooking area will not turn on but remains active/ selected.

When a surface cooking area is left at the “0” power level for 1 minute, the zone will automatically turn off and display only the middle dash without the indicator light.

Use the following chart as a guide when setting heat levels.

SETTING	RECOMMENDED USE
9 - Boost	■ Bring liquid to a boil.
9	■ Start food cooking.
7 - 8	■ Quickly brown or sear food.
6 - 7	■ Hold a rapid boil.
5 - 6	■ Fry or sauté foods. ■ Cook soups, sauces and gravies.
4 - 5	■ Maintain a slow boil. ■ Stew or steam food.
3 - 5	■ Range of simmer levels for simmering with or without a lid.
Melt	■ Melt chocolate or butter.
Simmer	■ Simmer sauces.
Dual surface cooking area	■ Home canning. ■ Large-diameter cookware. ■ Large quantities of food.

To Turn Off:

Press POWER.

1. Touch OFF to turn off desired surface cooking area. One tone will sound when Off is pressed.
2. Touch POWER to turn off the cooktop when finished.

Hot Surface Indicator

An “H” will appear in the heat setting display as long as any surface cooking area is too hot to touch, even after the surface cooking area(s) is turned off.

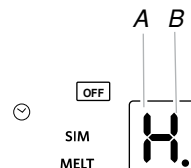

A. Heat setting display
B. Hot surface indicator “H”

Dual Size Surface Cooking Area (on some models)

The dual size surface cooking area offers flexibility to cook using different sizes of cookware. Single size can be used in the same way as a regular surface cooking area. The dual size combines inner and outer surface cooking areas and is recommended for larger cookware, large quantities of food, and home canning.

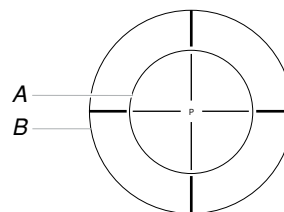

A. Single size
B. Dual size

The dual size surface cooking area contains two cooking areas. If the size of the pan is the same as the single size surface cooking area, the cooking area will work as a single size cooking area.

If the pan is slightly larger than the single size cooking area, it may activate only part of the dual size cooking area. This will result in the burner being less efficient and will increase the heating time.

If the size of the pan is the same as the dual size surface cooking area, the dual size cooking area will activate automatically.

Simmer

The Simmer function can be used with all surface cooking areas. Simmer can be used on more than 1 surface cooking area at a time.

To Use

To Turn On:

1. Check that a surface cooking area has been selected.
2. Touch SIMMER. "A" will appear in the display, and the indicator light next to Simmer will light.

The timer remains visible and can be set if desired.

To Turn Off:

Simmer can be turned off in 3 different ways:

1. Use the power slider to set to a heat level.
OR
2. Touch the surface cooking area OFF keypad.
OR
3. Select a different cooking function.

Melt + Hold

The Melt + Hold function can be used with all surface cooking areas. Melt + Hold can be used on more than 1 surface cooking area at a time.

To Use

To Turn On:

1. Check that a surface cooking area has been selected.
2. Touch MELT + HOLD. "A" will appear in the display, and the indicator light next to Melt + Hold will light.

The timer remains visible and can be set if desired.

To Turn Off:

Melt + Hold can be turned off in 3 different ways:

1. Use the power slider to set to a heat level.
OR
2. Touch the surface cooking area OFF keypad.
OR
3. Select a different cooking function.

Bridge (on some models)

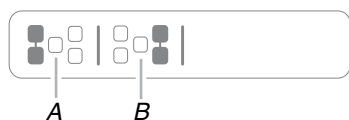

A. Left side bridge
B. Right side bridge

The Bridge function can be activated when surface cooking areas are on or when they are off. The Bridge function allows you to use 2 cooking zones as an extra-large cooking zone.

To Turn On a Bridge:

1. Touch the desired Bridge keypad (left side bridge or right side bridge).

The indicator light above the Bridge keypad will light. The heat setting levels for the 2 surface cooking areas will default to "0" and can be set from a minimum of "1" to a maximum of "9." Any timers that may be running for the 2 surface cooking areas will turn off, and 2 dashes "--" will appear in the timer display.

2. Slide a finger on the Heat Level Slider to change the power level up or down.

The selected heat level will show in the heat level display for each surface cooking area using the bridge.

To Turn Off a Bridge:

1. Touch the Bridge keypad for the zone being used (left side bridge or right side bridge).

The surface cooking areas will resume operation as 2 separate areas.

NOTE: Performance Boost cannot be used on the same elements in combination with the Bridge function.

Pan Detection

If a pan is removed from a surface cooking area when it is in use, the "no pan" indicator lights up. A flashing dash "--" will also appear in the display along with an "alert" tone for 1 minute. If the pan is not correctly replaced within 1 minute, the surface cooking area will switch Off.

If a Timer is running when a pan is removed the countdown will pause.

Control Lock

The Control Lock avoids unintended use of the surface cooking areas.

If Control Lock is activated when power to the cooktop is off, the cooktop is locked out, and the surface cooking areas cannot be turned on by the cooktop touch controls.

If Control Lock is activated when power to the cooktop is on, all keypads are locked out except for the Power and On/Off keypads.

To Lock Cooktop:

Touch and hold the CONTROL LOCK keypad for 3 seconds. After 3 seconds, a tone will sound and the indicator light above the Control Lock keypad will light, indicating that the cooktop controls are in the lockout position.

If the cooktop is in use when Control Lock is activated, cooking will proceed as normal and any timers that have been set will continue their countdown.

To Unlock Cooktop:

Touch and hold the CONTROL LOCK keypad for 3 seconds.

Performance Boost Function

This function allows you to increase the heat setting level above the maximum heat setting 9 for 10 minutes or less.

NOTE: Performance Boost is not available when the Bridge function is activated.

30" (76.2 cm) SIMU530

Performance Boost function is available on only 1 surface cooking area at a time within a zone. If you attempt to use another surface cooking area in the same zone, "P" and "9" will briefly flash in the display before returning to heat setting level 9. The surface cooking area that was set to the Performance Boost function will automatically reset to heat setting level 9. See the following illustrations for zones.

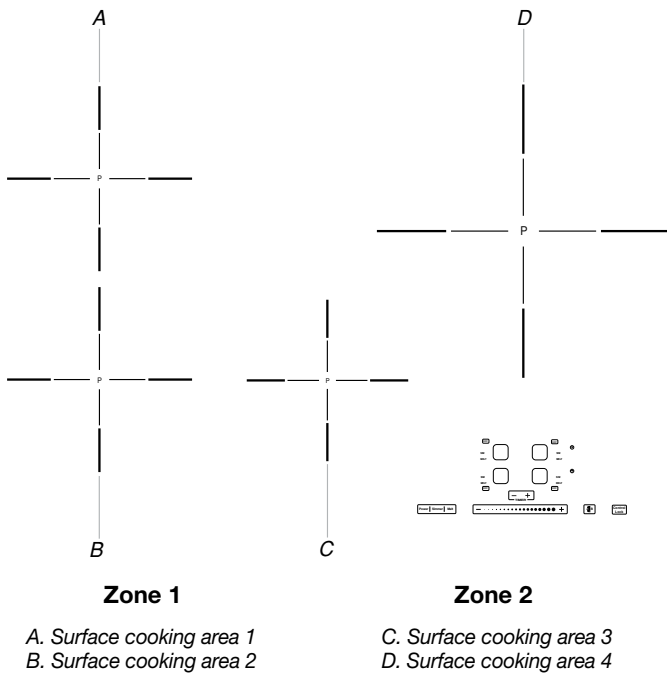

36" (91.4 cm) SIMU536

Performance Boost can be used on all surface cooking areas at the same time.

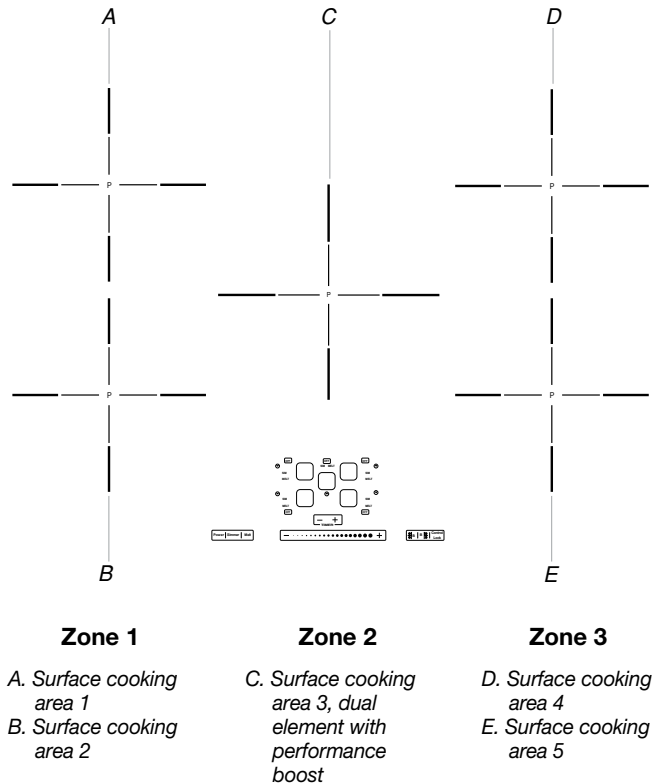

To Use:

1. Check that a surface cooking area has been selected.
2. Touch BOOST. "P" will appear in the display.
3. Touch BOOST keypad when finished. The "P" will no longer be visible in the display, and the Performance Boost function will no longer be active. The surface cooking area turns back to heat setting level 9.

NOTE: The Performance Boost function may automatically deactivate to keep the internal electronic components of the cooktop from becoming too hot.

Timer

Use the cooking timer to set times up to 90 minutes. The timer is independent of any other control settings. The timer can be used only on one cooking zone at a time.

To Use:

1. Touch the TIMER keypad. "01" will appear in the timer display.
2. Touch the ">" key to increase the time in 1-minute increments.
OR
Touch the "<" key to decrease the time in 1-minute increments.
3. The timer will start to count down after a few seconds. To change the time, touch the time ">" or "<" keypads.
4. When the countdown is finished, "00" flashes and a tone will sound.

NOTE: When the power is restored after an outage, the timer will no longer be running.

Tones

Tones are audible signals, indicating the following:

One tone

- Valid pad press
- Slider is moved to “0” power level
- Slider is moved to “Boost” power level

Two tones

- Invalid pad press

Three tones

- End of Timer cycle
-

Ceramic Glass

Cleaning off the induction cooktop before and after each use will help keep it free from stains and provide the most even heating. For more information, see “General Cleaning” section.

- Avoid storing jars or cans above the cooktop. Dropping a heavy or hard object onto the cooktop could crack the cooktop.
- To avoid damage to the cooktop, do not leave a hot lid on the cooktop. As the cooktop cools, air can become trapped between the lid and the cooktop, and the ceramic glass could break when the lid is removed.
- For foods containing sugar in any form, clean up all spills and soils as soon as possible. Allow the cooktop to cool down slightly. Then, while wearing oven mitts, remove the spills while the surface is still warm. If sugary spills are allowed to cool down, they can adhere to the cooktop and can cause pitting and permanent marks.
- To avoid scratches, do not slide cookware or bakeware across the cooktop.
- To avoid damage to the cooktop, do not allow objects that could melt, such as plastic or aluminum foil, to touch any part of the entire cooktop.
- To avoid damage to the cooktop, do not use the cooktop as a cutting board.
- Use cookware about the same size as the surface cooking area. Cookware should not extend more than ½" (1.3 cm) outside the area.

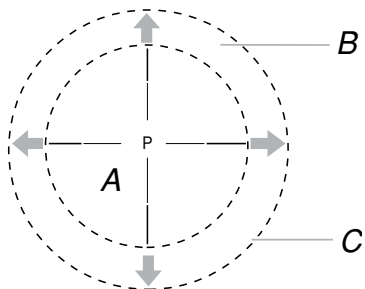

A. Surface cooking area
B. Cookware/canner
C. ½" (1.3 cm) Maximum overhang

- Use flat-bottomed cookware for best heat conduction and energy efficiency. Cookware with rounded, warped, ribbed or dented bottoms could cause uneven heating and poor cooking results.
 - Determine flatness by placing the straight edge of a ruler across the bottom of the cookware. While you rotate the ruler, no space or light should be visible between it and the cookware.
 - Make sure the bottoms of pots and pans are clean and dry before using them. Residue and water can leave deposits when heated.
-

Cookware

Only ferromagnetic pans can be used for induction cooking.

Ferromagnetic materials include:

- Enameled steel
- Cast iron
- Stainless steel designed for induction cooking

Non-ferromagnetic materials include:

These types of pans will not work with induction cooking.

- Stainless steel
- Glass
- Ceramic
- Copper or aluminum pans

To find out whether your pans can be used with an induction cooktop, flip the pan over, hold a magnet to the bottom of the pan, and see whether it sticks. If the magnet sticks to the bottom of the pan, the pan is ferromagnetic and can be used for induction cooking.

The number on the surface cooking area heat setting display will flash if no pan is placed on the surface cooking area, or the pan is not made of the right material, or it is not the right size. It will stop flashing once a suitable pan is placed on the surface cooking area. If you take longer than 90 seconds to place the correct pan on the surface cooking area, the surface cooking area will turn off.

Ideal cookware should have a flat bottom, straight sides and a well-fitting lid, and the material should be of medium-to-heavy thickness.

Choose the correct pan size for each surface cooking area. The diameter of the pan's base should correspond to the size of the surface cooking area.

NOTE: Cookware manufacturers often give the diameter across the top of the pan. This is usually larger than the diameter of the base.

Pans with rough finishes may scratch the cooktop.

COOKTOP CARE

General Cleaning

IMPORTANT: Before cleaning, make sure all controls are off and the cooktop is cool. Always follow label instructions on cleaning products.

Soap, water and a soft cloth or sponge are suggested first unless otherwise noted.

CERAMIC GLASS

To avoid damage, do not use steel wool, abrasive powder cleansers, chlorine bleach, rust remover or ammonia.

Cleaning Method:

Always wipe with a clean, wet cloth or sponge and dry thoroughly to avoid streaking and staining.

Cooktop cleaner is recommended for regular use to help avoid scratches, pitting and abrasions, and to condition the cooktop. It may be ordered as an accessory.

A cooktop scraper is also recommended for stubborn soils.

Light to moderate soil

- Paper towels or clean damp sponge.
- Cooktop cleaner and clean damp paper towel:
Clean as soon as cooktop has cooled down. Rub creme into surface with a damp paper towel or soft cloth. Continue rubbing until white film disappears.

Sugary spills (jellies, candy, syrup)

- Cooktop scraper:
Clean while the cooktop is still warm. You may want to wear oven mitts while cleaning the cooktop.

Heavy soil, dark streaks, specks, and discoloration

- Cooktop cleaner or nonabrasive cleanser:
Rub product into soil with a damp paper towel or soft cloth. Continue rubbing until white film disappears.

Burned-on soil

- Cooktop cleaner and Cooktop scraper:
Rub creme into soil with damp paper towel. Hold scraper as flat as possible on surface and then scrape. Repeat for stubborn spots. Polish entire cooktop with creme and paper towel.

Tiny scratches and abrasions

- Cooktop cleaner:
Rub creme into surface with a damp paper towel or soft cloth. Continue rubbing until white film disappears. Scratches and abrasions do not affect cooking performance and after many cleanings become less noticeable.

TROUBLESHOOTING

Try the solutions suggested here first in order to avoid the cost of an unnecessary service call.

Nothing will operate

- **Is the cooktop wired properly?** See the Installation Instructions for more information.
- **Has a household fuse blown, or has a circuit breaker tripped?** Replace the fuse or reset the circuit breaker. If the problem continues, call an electrician.

Cooktop will not operate

- **Is the cooktop control set correctly?** Touch the display area on the control panel to select a cooking surface before selecting a function.
- **Is the “Control Lock” Cooktop Lockout set?** See “Control Lock” section.
- **Has the cooktop turned off by itself?** The power off key was unintentionally touched. Press power key again. Reset the cooktop.

Excessive heat around cookware on cooktop

- **Is the cookware the proper size?** Use cookware about the same size as the surface cooking area. Cookware should not extend more than ½" (1.3 cm) outside the cooking area.

Cooktop cooking results not what expected

- **Is the proper cookware being used?** See “Cookware” section.
- **Is the cooktop control set to the proper heat level?** See “Cooktop Controls” section.
- **Is the cooktop level?** Level the cooktop. See the Installation Instructions.

Display shows messages

- **Is the display flashing when you place a saucepan on an induction surface cooking area?** Check that the saucepan is electromagnetic. Check that the diameter of the saucepan is large enough. Center the saucepan on the surface cooking area. Allow the saucepan to cool down in the event that it has become hot when used. Switch the surface cooking area off and then on again. If the display still does not light up, turn power off at the circuit breaker. Wait 20 seconds and turn power back on.
- **Is the Performance boost function display flashing and switching off?** The Performance boost function operates the surface cooking area with the most power. During long cooking times, it is possible that the function will switch the surface cooking area off to keep the cooktop from overheating. You can continue to use the cooktop if the display is not flashing.

- **Is the display flashing “Er” and numbers?** If an “Er” and a series of numbers appear in the display panel, turn power off at the circuit breaker. Turn on again. If problem continues, call customer service.
- **Is the display flashing “F” or “C” and numbers?** If “F” or “C” and a number are alternately flashing on the display, refer to the following table for possible solutions.

Error Code	Error	Solution
Cooktop has turned off and is beeping every 10 sec.	An object, liquids or soils are putting pressure on the control panel.	Thoroughly wipe or remove any object on touch keys.
F42, F43	The power voltage is too low or too high.	Turn off the cooktop. Wait 5 seconds, then turn it back on. If this continues, contact a qualified electrician.
C81, C82, C83	The surface cooking area has overheated.	The surface cooking area automatic shutoff was activated. Wait 5 minutes for it to cool down, and then turn it back on. Turn off oven if it is running a self cleaning cycle.
F12, F21, F25, F36, F37, F40, F47, F56, F58, 560, F61, F62, F63, F64		Call customer service.

Operational cooktop sounds

- **Is there a low humming?** This occurs when cooking at high power. The cause of this is the amount of energy that is transmitted from the appliance to the cookware. This sound will quiet or go away when the power is turned down.
- **Is there a crackling?** This sound occurs when cookware is used that consists of different materials. The noise is caused by vibrations in the joint faces between the different layers. It may change depending on the amount and type of food being cooked.
- **Is there a fan noise?** The electronics require a controlled temperature in order to function reliably. The cooktop is fitted with a fan that runs at various speeds according to the temperature detected. The fan may also continue to run even after the cooktop has been switched off if the temperature it detects is too high.

Please record your model (MOD) and serial number (S/N) below for future reference. For your convenience, a label containing this information is supplied with this booklet.

When writing or calling about a service problem, please include the following information:

- your name, address and telephone number
- appliance model and serial number
- name and address of your dealer
- a clear description of the problem you are having
- proof of purchase (sales receipt)

SMEG BUILT-IN ELECTRIC COOKTOP WARRANTY

FULL ONE-YEAR WARRANTY

For one year from the date of the original purchase, SMEG USA, Inc. ("SMEG") will repair or replace (at its option) any part of the cooktop which fails due to a defect in materials or workmanship. During this full one year warranty, SMEG will provide, free of charge, all labor and in-home service to repair or replace the defective part.

LIMITED TWO YEAR WARRANTY

For two years from the date of the original purchase, SMEG will repair or replace (at its option) the glass ceramic surface and any of the cooking zones that fail in normal home use. If any new part is required, this will be supplied by SMEG, free of charge. All other costs, including labor to repair or replace the defective part, mileage, transportation, trip charge and diagnostic charge, if required, shall be the responsibility of the owner.

These warranties are extended to the original purchaser and any succeeding owner with proper documentation of ownership for products purchased for residential use within the United States of America and Canada.

The benefits offered by these warranties are in addition to customer's rights and remedies under United States of America or Canada law.

EXCLUSIONS

This warranty does not cover any defect or damage, which is not direct fault of Smeg; this includes, but is not limited to:

- 1) Service trips to your home to instruct you how to use the product.
- 2) Service trips to your home, during which no fault is found.
- 3) Damages occurred during transit, handling and/or installation of the product.
- 4) Damages occurred in case the product has not been installed, duly following the manufacturer's installation instructions, as well as any local code or regulation.
- 5) Damages due to failure in following the manufacturer's recommended cleaning and maintenance instructions; in particular, damages to the glazed ceramic cooktop if it has not been cared and cleaned according to these instructions.
- 6) Damages to the glass ceramic surface, in case the damage is not directly related to a defect of the part itself; in particular, cracking or breaking of the glass ceramic surface due to any impact of objects falling on it.
- 7) Any repair, modification, alteration, or adjustment provided by any person not authorized by SMEG.
- 8) Failure of the product if it is abused, misused or used for other than the intended purpose or if used commercially/industrially.
- 9) Incorrect electric current, voltage or power supply.
- 10) Improper setting of any control.
- 11) Replacement of house fuses or resetting of circuit breakers.
- 12) Wear and tear
- 13) Any substance, accumulating in any part or component of the product.
- 14) Damages to anything situated next to the product, including, but not limited to, ceiling, floor or cabinetry.
- 15) Damage to the product caused by accident, fire, floods or acts of God.
- 16) Expenses for travel and transportation to locations more than 30 miles from an authorized SMEG retailer.
- 17) Products with original serial numbers that have been removed.

The remedies described above are the only ones which SMEG will provide, either under this warranty or under any warranty arising by operation of law. SMEG will not be responsible for any consequential or incidental damages arising from the breach of this warranty or any other warranty, whether express, implied or statutory.

Some states do not allow the exclusion or limitation of incidental or consequential damages. This warranty gives you specific legal rights, and you may also have other rights which vary from state to state. To know what your legal rights are, consult your local state consumer affairs office or your state's Attorney General.

FOR SERVICE OR TECHNICAL INQUIRIES:

- CONTACT SMEG USA SERVICE CENTER AT: 1-888-SMEG-SVC (1-888-763-4782)
Only for CANADA: calls from Canada will be automatically forwarded to the local Service Agent.

FOR ALL OTHER INQUIRIES:

- WRITE TO: SMEG USA, Inc - 150 EAST 58th STREET 7th FLOOR, NEWYORK, NY 10155; or
- CALL SMEG USA, Inc AT: 1-866-736-SMEG (1-866-736-7634)

Notes