

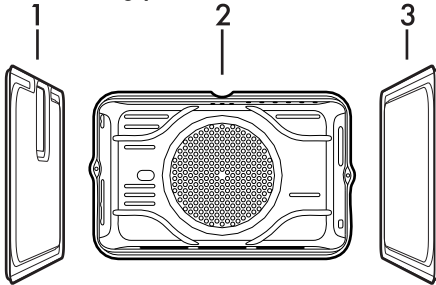

Self-cleaning panels

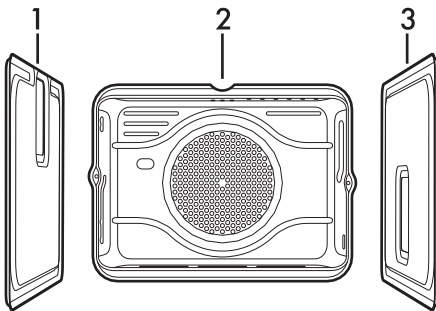

PC60



PC68 - PC681

- 1 Left self-cleaning panel
- 2 Self-cleaning deflector
- 3 Right self-cleaning panel

The self-cleaning panels are coated in a special enamel which aids progressive elimination of grease splattering and odours caused by cooking food.

Precautions

Avoid using anti-adhesive films (silicone) and all maintenance products, particularly harsh cleaning products.

Do not knock the self-cleaning coating or use metal brushes or blunt objects to clean it.

Practical advice

The self-cleaning enamel will always remain clean as long as stains are not produced at a greater rate than they are eliminated.

If production of stains increases, the cleaning action will become insufficient and the self-cleaning coating will become ineffective.

After cooking food which leaves a large amount of dirt and stains on the oven (e.g. roast duck), it is necessary to heat the oven up to maximum temperature while empty.

Cooking foods which do not splatter can also be an opportunity to perform this regeneration.

Do not cook food which could further stain the oven before the dirt from the previous cooking has been eliminated.



If the appliance has the "Vapor Clean" function, do not point the spray nozzle towards the deflector.



Installation of the self-cleaning panels

1. Remove all accessories from inside the oven (trays and drip trays).
2. Remove the frames: pull the frame towards the inside of the oven to unhook it from its groove **A**, then slide it out of the seats at the back **B**.

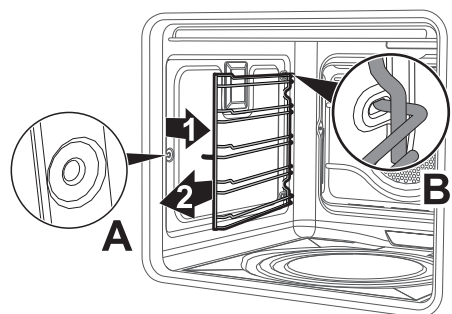
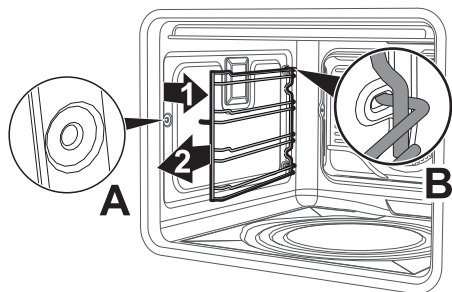

3. Remove the deflector: unscrew the two side screws holding the deflector to the rear wall of the oven.

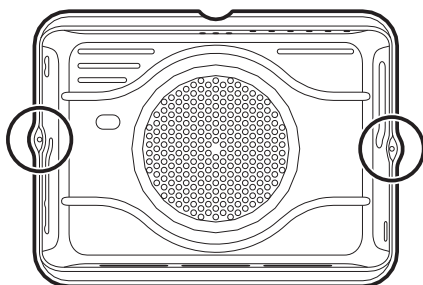
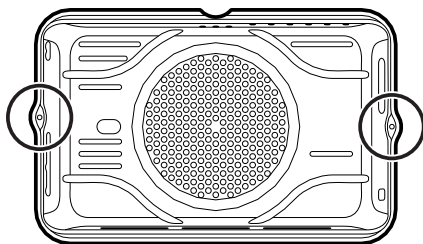

4. Replace the deflector with the new self-cleaning deflector (**2**): fasten it to the rear wall of the oven using the screws removed from the previous deflector.



- Place the left-hand self-cleaning panel (1) on the corresponding oven wall.
- Hold the self-cleaning panel in position on the wall and insert the frame first into the seats at the back B, then hook it into its groove A.

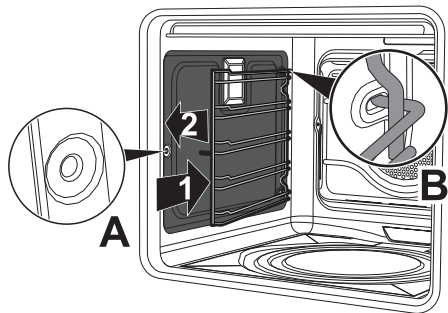
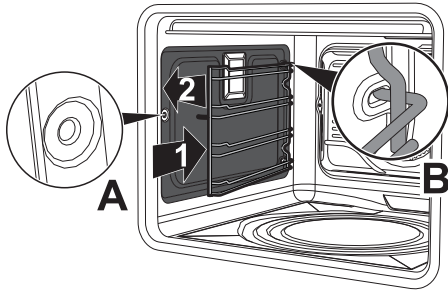

- Repeat the operation with the right-hand self-cleaning panel (3).

Regeneration of self-cleaning panels (catalytic cycle)

The regeneration cycle of the self-cleaning panels is a cleaning method through heating suitable for removing small grease residues, not sugar-based ones.

- Clean the base and the upper guard first with a microfibre cloth soaked in water and neutral washing up liquid. Rinse thoroughly.
- Set a regeneration cycle by selecting a fan assisted function at the maximum temperature for one hour.
- If the panels are particularly dirty after the regeneration cycle, remove them and wash them with neutral washing up liquid. Rinse and dry them.

Put the panels back in the oven and set a fan assisted function at a temperature of 180°C for one hour, in order to ensure that they are thoroughly dry.



We recommend carrying out the self-cleaning panel regeneration cycle every 15 days.



Preliminary operations (only for appliances with "Vapor Clean")

Before starting the Vapor Clean function:

- Completely remove all accessories from inside the oven. The upper guard can be left inside the oven.
- Remove the self-cleaning panels and racks/trays support frames.
- Spray a water and washing up liquid solution inside the oven using a spray nozzle. Direct the spray against the side walls, upwards and downwards.

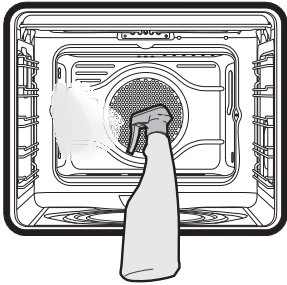

Do not spray towards the deflector.